

Digital
Human Machine Interface

SCIENCE GATE
Your Automation Partner



SCIGATE AUTOMATION (S) PTE LTD
No.1 Bukit Batok Street 22 #01-01 Singapore 659592
Tel: (65) 6561 0488 Fax: (65) 6562 0588
Email: sales@scigate.com.sg Web: www.scigate.com.sg
Business Hours: Monday - Friday 8.30am - 6.15pm

Pro-face

FP-2500/FP-2600 Series User Manual

Digital
Digital Electronics Corporation

Preface

Thank you for purchasing Digital's TFT type color display panel, the FP-2500/FP-2600 Series unit (hereafter referred to as the *FP unit or FP Series*).

Please read this manual completely to ensure the correct use and complete understanding of the FP unit's functions.

<Note>

- 1) It is forbidden to copy the contents of this manual, in whole or in part, except for the user's personal use, without the express permission of Digital Electronics Corporation of Japan.
- 2) The information provided in this manual is subject to change without notice.
- 3) This manual has been written with care and attention to detail; however, should you find any errors or omissions, please contact Digital Electronics and inform them of your findings.
- 4) Regardless of the above clause, Digital Electronics Corporation shall not be held responsible for any damages or third-party claims for damages or losses resulting from the use of this product.

All Company/Manufacturer names used in this manual are the registered trademarks of their respective companies.

© 2004, Digital Electronics Corporation

Essential Safety Precautions

This manual describes safety instructions for correct use of the FP unit. Please keep this manual close at hand and refer to it when necessary.

The following symbols are used throughout this manual to ensure the safe use of the FP unit. Please be sure to follow all instructions given since they explain important safety points.



Indicates situations where severe bodily injury, death or major equipment damage will occur.



Indicates situations where bodily injury or machine damage can occur.

WARNINGS

- **Prior to connecting the FP-2500/FP-2600 Series (hereafter referred to as the “FP” or FP unit) unit’s power cord terminals to the Terminal Block, be sure to check that the FP unit’s power supply is completely turned OFF, via a breaker, or similar unit.**
- **Do not use voltage levels that exceed the FP unit’s specified voltage range. Doing so may cause a fire or an electric shock.**
- **Since the FP unit contains high voltage parts, an electric shock can occur when opening the unit. Therefore, be sure to unplug the power cord before opening it.**
- **Do not modify or remodel the FP unit. Doing so may lead to a fire or electric shock.**
- **Do not use FP unit touch panel switches in human-safety-related or important disaster prevention situations. For safety-related switches, such as an emergency stop switch, be sure to use a separately installed mechanical switch.**
- **Do not use the FP unit as a warning device for critical alarms that can cause serious operator injury, machine damage or production stoppage. Critical alarm indicators and their control/activator units must be designed using stand-alone hardware and/or mechanical interlocks.**

 **WARNINGS**

- **After the FP unit's backlight burns out, unlike the FP unit's "Standby Mode", the touch panel is still active. If the operator fails to notice that the backlight is burned out and touches the panel, a potentially dangerous machine operation error can occur. Therefore, do not use FP touch switches for the control of any equipment safety mechanisms, such as Emergency Stop switches, etc. that protect humans and equipment from injury and damage.**
If your FP unit's backlight suddenly turns OFF, use the following steps to determine if the backlight is actually burned out.
 - 1) **If your current FP application is not set to turn the backlight OFF, and the screen has gone blank, your backlight is burned out.**
 - 2) **If your current FP application is set to turn the backlight OFF, and if touching the screen does not cause the display to reappear, your backlight is burned out.**
- **If substantial amounts of metallic dust, water or liquids enter the FP unit, turn OFF the power supply immediately, unplug the power cord, and contact your local FP distributor.**
- **When installing the FP unit, be sure to follow the instructions given in "Chapter 3 Installation and Wiring".**
- **Do not use the FP in an environment where flammable gases are present, since operating the FP may cause an explosion.**
- **Do not use the FP with aircraft control devices, aerospace equipment, central trunk data transmission (communication) devices, nuclear power control devices, or medical life support equipment, due to these devices' inherent requirements of extremely high levels of safety and reliability.**
- **When using the FP with transportation vehicles (trains, cars and ships), disaster and crime prevention devices, various types of safety equipment, non-life support related medical devices and others, be sure to use redundant and/or failsafe system designs to ensure the appropriate degree of system reliability and safety.**
- **To prevent operator injury or machine damage, be sure to design your machine operation system so that the machine will not malfunction due to a communication fault between the FP unit and its PC host controller.**



CAUTIONS

- Do not strike the FP unit's touch panel with a hard or heavy object, or press on the touch panel with too much force, since it may damage the display.
- When the surface of the display screen becomes dirty or smudged, clean the display with a cloth soaked in a neutral detergent. Do not use paint thinner or organic solvent.
- Do not press on the touch panel's face with sharp objects, such as a mechanical pencil or screwdriver, since it might damage the LCD panel.
- Do not use or store the FP in direct sunlight, excessively dusty or dirty environments, or where chemicals or their vapors are present in the air.
- Do not restrict the FP unit's natural ventilation, or store or use the FP in an environment that will increase the FP's internal temperature.
- Do not use the FP in areas where sudden, large changes in temperature may occur. These changes can cause condensation to form inside the unit, possibly leading to a malfunction.
- When the product is disposed of, it should be done so according to your country's regulations for similar types of industrial waste.



Notes on the FP unit's Liquid Crystal Display (LCD)

- The FP unit's LCD contains a strong irritant. If the panel is damaged and the LCD unit's liquid contacts your skin, be sure to wash it with running water for at least 15 minutes. If any of this liquid should enter your eye, be sure to flush the eye with running water for more than 15 minutes, and see a doctor immediately.
- The brightness of the LCD screen will depend on the screen's current display and the LCD unit's contrast adjustment. Any brightness variations that result are normal for LCD displays.
- There are minute grid-points on the LCD surface. These points are not defects.

- The displayed color will look different when viewed from an angle outside the specified view angle. This is also normal.
- Displaying a single screen image for long periods of time can cause an afterimage to remain. To correct this, turn the unit OFF for 5 or 10 minutes, then turn it ON again. This phenomenon is a common attribute of the LCD unit's and not a defect. To prevent this effect, you can:
 - use the Display OFF feature, if the same image is to be displayed for a long period of time.
 - change the screen display periodically to prevent the displaying of a single image for a long period of time.

Documentation Conventions

The list below describes the documentation conventions used in this manual.

Symbol	Meaning
	Indicates important information or procedures that must be followed for correct and risk-free software/device operation.
	Refers to useful or important supplemental information.
	Provides useful or important supplemental information.
*1	Indicates useful or important supplemental information.
1) , 2)	Indicates steps in a procedure. Be sure to perform these steps in the order given.

FP-2500/FP-2600 Series Models

The FP-2500/FP-2600 Series refers to the following FP model numbers:

Series	Model Name	Model Type	Power Input Type	Standards
FP-2500	FP-2500T	FP2500-T12	AC	-
		FP2500-T42-24V	DC	UL/c-UL/CSA Approved, CE Marked
FP-2600	FP-2600T	FP2600-T12	AC	-
		FP2600-T42-24V	DC	UL/cUL Approved, CE Marked

FP-2500/FP-2600 Series Features

■ High Quality TFT Color LCD Display

The FP-2500 Series units are equipped with a 10.4 inch TFT type color LCD and the FP-2600 Series units are equipped with a 12.1 inch TFT type color LCD. Both have superb brightness and wide viewing angles, not found in ordinary laptop-type TFT LCDs.

The FP-2500 Series units screen's maximum resolution is 640(H) X 480(W) pixels and the FP-2600 Series units are 800(H) X 600(W) pixels. Both can display 260,000 colors.

■ Easy Installation In User Cabinets and Panels

The FP unit's slim and compact design makes installation a snap. These panels are designed specifically for IA (Industrial Automation) or OA (Office Automation) monitor. The flat front panel provides protection equivalent to IP65. Even without its optional protective cover the front panel is highly resistant to both water and dust.

■ Panel can be used as a Display

Since the FP is equipped with an analog RGB interface and a DVI-D Interface, it can be connected to a PC and other similar devices easily. (The PC's dot clock frequency, however, must be within the standard range.)

■ Easy-to-use Built-In Touch Panel

The FP unit's built-in touch panel is standard equipment, allowing touch panel data to be output to a host PC via input/output commands and an RS-232C or USB cable. This is ideal for systems requiring both touch panel operation and data monitoring.

Connecting the FP to a PC

The FP-2500 Series units are designed for standard VGA mode display and the FP-2600 Series units are designed as a standard SVGA display.

Be aware that some types of VGA/SVGA equipment may not be within the ranges specified in this document, and, therefore, cannot be connected to the FP.

Also, if you change your PC's VGA/SVGA board, there is the possibility that the new board may not be able to be connected to the FP.

Reference 2.3 Interface Specifications



- **When a signal timing value not compatible with the FP unit is entered, or if the entered timing value is larger than can be displayed by the dot clock, an "OUT OF RANGE" message is displayed. If this occurs, consult your computer's manual and enter a value that is compatible with this device.**
- **If no signal (synchronized signal) is entered, a "NO SIGNAL" message is displayed.**

What is IP65f?

This code indicates the degree of ingress protection provided from the front face of the FP, and assumes that the FP is securely mounted into a metal panel.

This unit's protection rating of IP65f is actually a composite code, consisting of the internationally recognized British "Ingress Protection" standard (BS EN 60529:1992) - "IP65", and the standard developed by the Japanese Electronics Manufacturer's Association (JEM) - "f". This code is used in this manual to identify this product's degree of structural resistance to a variety of environmental elements and thus, prevent problems or accidents related to the inappropriate product use.

The individual meaning of each character of this code is explained below.

IP 6 5 f

(1) (2) (3) (4)

- (1) Designates the type of protection provided.
- (2) Indicates the degree of protection provided to the human body by the unit, and the degree of protection provided by the unit's front face from particles/dust intrusion into the interior of the unit.
Here, "6" indicates that the unit is completely protected from dust intrusion.
- (3) Indicates the degree of protection provided by the unit's front face from water intrusion into the interior of the unit.
Here, "5" indicates that the unit is protected from water intrusion from a direct water jet.
- (4) Indicates the degree of protection provided by the unit's front face from oil particle intrusion into the interior of the unit.
Here, "f" indicates that the unit is completely protected from oil intrusion via either oil particles or oil splashes from any direction (to the front panel).

Package Contents

The FP unit's packing box contains the items listed below. Please check to be sure each item is included and is not damaged.

■ FP unit (1)

(FP2500-T12/FP2600-T12/
FP2500-T42-24V/FP2600-T42-24V)

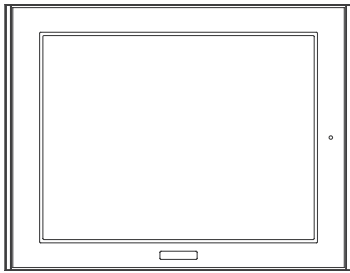

■ CD-ROM (1)

(FP-2500/FP-2600 Series User Manual &
Touch Panel Communication Programs
For MS-DOS®)



■ Installation Gasket (1)

(Attached to the FP unit)



■ Installation Fasteners (4)

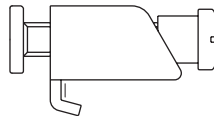

■ Installation Guide (1)

(Japanese/English)

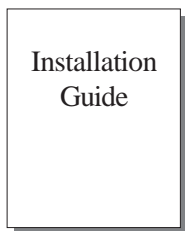

■ USB Cable Strap (1)



These items have all been carefully packed with special attention to product quality. However, should you find anything damaged or missing, please contact your local FP distributor immediately for prompt service.

UL/c-UL/CSA Application Notes

The FP2500-T42-24V/FP2600-T42-24V units are UL/c-UL listed products (UL File No. E182139).

The FP conforms as a component to the following standards:

- **UL508** Industrial Control Equipment
- **UL1604** Electrical Equipment for use in Class 1 & 2 - Division 2, and Class III Hazardous (classified) locations.
- **CAN/CSA-C22.2, No.1010-1** Measurement and Control Equipment Safety requirements for electrical equipment for measurement and laboratory use.

FP2500-T42-24V (UL Registration Model No.:3280033-02)

FP2600-T42-24V (UL Registration Model No.:3280033-04)

<Cautions>

Be aware of the following items when building the FP into an end-use product:

- The FP unit's rear face is not approved as an enclosure. When building the FP unit into an end-use product, be sure to use an enclosure that satisfies standards as the end-use product's overall enclosure.
- The FP unit must be used indoors only.
- This unit should be installed in the front face of a metal panel.
- If the FP unit is installed so as to cool itself naturally, be sure to mount it in a vertical panel. Also, be sure that the FP unit is installed at least 100 mm away from any adjacent structures or machine parts. If these conditions are not met, the heat generated by the FP unit's internal components may cause the unit to fail to meet UL standards.

UL1604 Conditions of Acceptability and Handling Cautions:

1. Power, input and output (I/O) wiring must be in accordance with Class I, Division 2 wiring methods - Article 501- 4(b) of the National Electrical Code, NFPA 70 within the United States, and in accordance with Section 18-152 of the Canadian Electrical Code for units installed within Canada.
2. Suitable for use in Class I, Division 2, Groups A, B, C and D, Hazardous Locations.
3. **WARNING:** Explosion hazard - substitution of components may impair suitability for Class I, Division 2.
4. **WARNING:** Explosion hazard - when in hazardous locations, turn power OFF before replacing or wiring modules.
5. **WARNING:** Explosion hazard - do not disconnect equipment unless power has been switched OFF, or the area is known to be non-hazardous.
6. **WARNING:** Explosion hazard - do not connect/disconnect equipment unless area is known to be nonhazardous.

CE Marking Notes

The FP2500-T42-24V/FP2600-T42-24V are CE marked products that conform to EMC directives EN55011 Class A and EN61000-6-2.

For detailed CE marking information, please contact your local FP distributor.

Revision Version

The revision version can be determined by the identification label or revision stickers that are placed on the main unit of the FP. The characters and numerals in the "REV" area that are replaced with asterisks (*), or marked with a marker indicate the revision version.

In the example below, the asterisks "*" are placed at positions "D", "1", and "2", which indicates the revision version as "D, 1, 2".

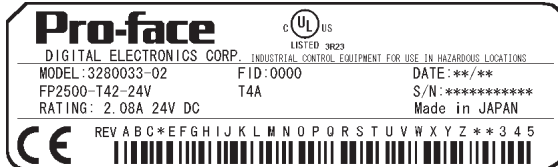

Identification Label

CD-ROM Data

The following data and programs are contained in the FP-2500/FP-2600 Series unit's CD-ROM.



FP2000-MMCD-02

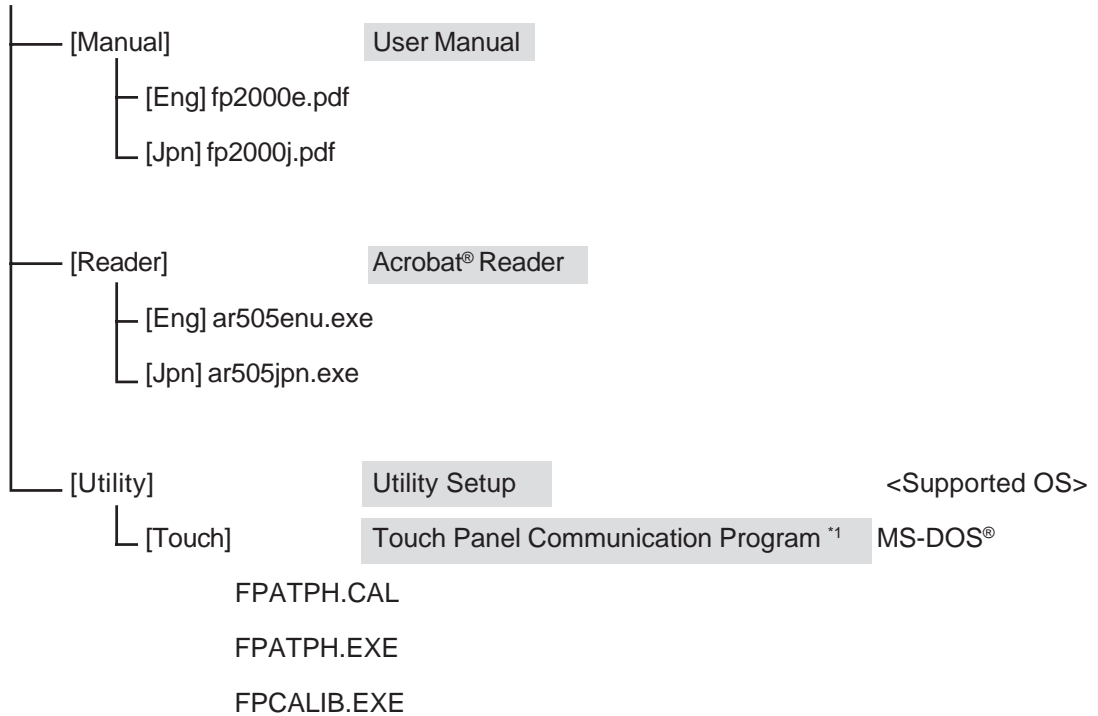

*1 These programs are only for MS-DOS® and FP-2500 series unit. When using Windows®95, WindowsNT®4.0, Windows®98, Windows®2000 and Windows®XP, the Mouse Emulator V2 (PL-TD000) is required.

Reference 1.2 Optional Equipment

Table of Contents

Preface	1
Essential Safety Precautions	2
Documentation Conventions	5
FP-2500/FP-2600 Series Models	6
FP-2500/FP-2600 Series Features	6
Connecting the FP to a PC	7
What is IP65f?	7
Package Contents	8
UL/c-UL/CSA Application Notes	9
CE Marking Notes	9
Revision Version	10
CD-ROM Data	10

Chapter 1 Introduction

1.1 System Design	1-1
1.2 Optional Equipment	1-2

Chapter 2 Specifications

2.1 General Specifications	2-1
2.1.1 Electrical	2-1
2.1.2 Environmental	2-2
2.1.3 Structural	2-2
2.2 Functional Specifications	2-3
2.2.1 Performance	2-3
2.2.2 Display	2-3
2.3 Interface Specifications	2-4
2.3.1 Analog RGB Interface	2-4
2.3.2 DVI-D Interface	2-7
2.3.3 RS-232C Interface	2-9
2.3.4 USB Interface	2-10

Table of Contents

2.4 Cable Diagrams	2-11
2.4.1 Analog RGB Interface Pin Connections (Optional cable)	2-11
2.4.2 DVI-D Interface Pin Connections (Optional cable)	2-12
2.4.3 RS-232C Interface Pin Connections (Optional cable)	2-13
2.4.4 USB Interface Cable Pin Connections (Option cable)	2-13
2.5 Names and Functions of FP Parts	2-14
2.6 FP Dimensions	2-15
2.6.1 External Dimensions	2-15
2.6.2 External Dimensions (with Installation Fasteners)	2-16
2.6.3 Installation Fasteners	2-17
2.6.4 FP Panel Cut Dimensions	2-17

Chapter 3 Installation and Wiring

3.1 Installation.....	3-1
3.1.1 Installation Procedures	3-1
3.2 Wiring Cautions	3-6
3.2.1 Connecting the Power Cord	3-6
3.2.2 Connecting the USB Cable Strap Attachment	3-8
3.2.3 Connecting the Power Supply	3-9
3.2.4 Precautions: Grounding	3-10
3.2.5 Precautions: Input/Output Signal Lines	3-10

Chapter 4 Setting up and Adjusting the FP unit

4.1 Operation Mode Setup	4-1
4.1.1 Dip Switch Preset Settings and Adjustments	4-1
4.1.2 Status of Front LED in Operation Modes	4-2
4.2 Screen Display Adjustment	4-2
4.2.1 Calibration of OSD Display Position	4-2
4.2.2 OSD Setting Icons	4-3
4.2.3 OSD Setting Item Details	4-4

Chapter 5 Touch Panel Data

5.1 Touch Interface Data	5-1
5.2 Touch Panel Communication Programs For MS-DOS®	5-4
5.2.1 FPATPH.EXE (Touch Panel Handler)	5-4
5.2.2 FPCALIB.EXE (Touch Panel Data FPCalibration)	5-8

Chapter 6 Troubleshooting

6.1 Troubleshooting	6-1
6.1.1 Possible Device Problems	6-1
6.1.2 No Display	6-2
6.1.3 Touch Panel Does Not Respond	6-4
6.2 Error Message	6-5
6.2.1 Error Message List	6-5

Chapter 7 Maintenance

7.1 Regular Cleaning	7-1
7.1.1 Cleaning the Display	7-1
7.1.2 Installation Gasket Replacement	7-2
7.2 Periodic Check Points	7-3
7.3 Backlight Replacement	7-4
7.3.1 Replacing GP577RT-BL00-MS	7-6
7.3.2 Replacing PS600-BU00	7-8
7.3.3 Replacing CA3-BLU12-01	7-10

Memo

Chapter 1

Introduction

1. System Design
2. Optional Equipment

1.1 System Design

The FP can be connected to Pro-face's PS-2000B or to a Windows® compatible PC.

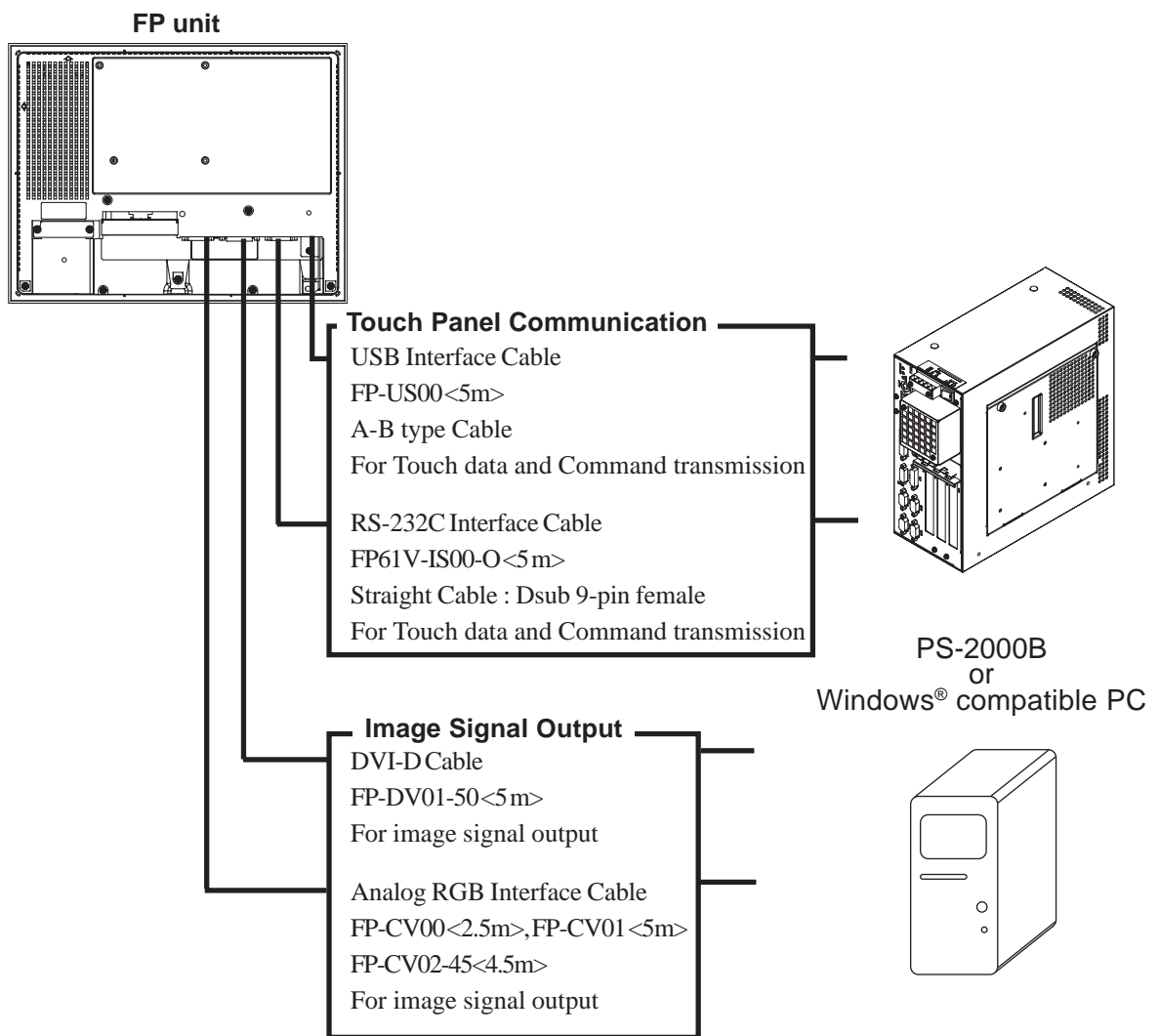

Note: The FP unit's dip switches set the type of communication method used for sending touch data and commands (USB or RS-232C), and also for outputting image signals (DVI-D or Analog RGB).

Reference 4.1.1 Dip switch setting

1.2 Optional Equipment

1.2 Optional Equipment

All optional items listed below are Digital Electronics Corporation products.

■ Cables

Item	Model Number	Description
RS-232C Cable	FP61V-IS00-O (5m)	Serial interface cable used for touch panel data transmission between the host and the FP or command transmission to the FP. This is a straight Dsub 9-pin female cable.
Analog RGB Cable	FP-CV00 (2.5m) FP-CV01 (5m) FP-CV02-45 (4.5m)	Analog RGB interface cable used when image signals are output to the FP from the host. (Dsub 15-pin male).
USB Cable	FP-US00 (5m)	USB interface cable used for touch panel data transfer between the host and the FP or command transmission to the FP. A-B type cable.
DVI-D Cable	FP-DV01-50 (5m)	Digital Visual Interface cable used to send the image signal from the host to the FP. XGA specification DVI-D 24-pin male.

■ Maintenance Parts

Item	Model Number	Corresponding FP	Rev.	Description
Installation Fasteners	GP070-AT01	FP-2500 Series FP-2600 Series	-	Metal installation fasteners.
Rubber Gasket	GP570-WP10-MS	FP-2500 Series FP-2600 Series	-	Replacement rubber gasket, used when installing the FP. Same as the FP unit's original gasket.
Screen Protection Sheet	PSL-DF00	FP-2500 Series FP-2600 Series	-	Disposable, dirt resistant sheet for the FP unit's screen. The FP unit's touch panel can be used with this cover sheet attached. (5 sheets/set)
Backlight	GP577RT-BL00-MS	FP-2500 Series	-	Replacement backlight for FP-2500 Series units.
	PS600-BU00	FP2600-T12	Rev.1 is not marked.*1	Replacement backlight for FP-2600 Series units.
		FP2600-T42-24V	Rev.1 is not marked.*1	
	CA3-BLU12-01	FP2600-T12	Rev.1 is marked.*1	
FP2600-T42-24V		Rev.1 is marked.*1		

*1 The corresponding backlight unit differs depending on FP-2600 Series unit's marked Revision.

Reference For more information on how to determine the revision version, see "Revision Version" (Page 10).

1.2 Optional Equipment

■ Available Software

Item	Model Number	Description
Mouse Emulator V2 *1	PL-TD000	Mouse emulation software for the FP.

**1 OS can be Windows®95, WindowsNT®4.0, Windows®98, Windows®2000 or Windows®XP .*

1.2 Optional Equipment

Memo

Chapter 2

Specifications

1. General Specifications
2. Functional Specifications
3. Interface Specifications
4. Cable Diagrams
5. Names and Functions of FP Parts
6. FP Dimensions

2.1 General Specifications

2.1.1 Electrical

■ FP2500-T12/FP2600-T12

Rated Voltage	AC 100V to AC 240V
Rated Voltage Range	AC 85V to AC 264V
Rated Frequency	50/60 Hz
Rated Frequency Range	47 Hz to 63 Hz
Allowable Voltage Drop	20ms or less
Power Consumption	50VA (ACIN 100V)/85VA (ACIN 240V)
Voltage Endurance	AC1500V 20mA for 1 minute (between charging and FG terminals)
Insulation Resistance	10M Ω or higher at DC500V (between charging and FG terminals)

■ FP2500-T42-24V/FP2600-T42-24V

Rated Voltage	DC24V
Rated Voltage Range	DC19.2 to DC28.8V
Allowable Voltage Drop	10ms or less
In-rush Current	30A or less
Power Consumption	50W or less
Voltage Endurance	AC1000V 20mA for 1 minute (between charging and FG terminals)
Insulation Resistance	10M Ω or higher at DC500V (between charging and FG terminals)

2.1 General Specifications

2.1.2 Environmental

	FP2500-T12 FP2600-T12	FP2500-T42-24V FP2600-T42-24V
Ambient Operating Temperature	0°C to +50°C ^{*1} (the panel face should not incline more than 30°C)	
Storage Temperature	-10°C to +60°C	
Ambient Humidity	30%RH to 90%RH	
	(Non condensing, wet bulb temperature: 39°C or less)	
Air Purity (Dust)	Free of dust	
Pollution Degree	Pollution Degree 2	
Corrosive Gasses	Free of corrosive gasses	
Vibration Resistance	10Hz to 25Hz 19.6m/s ²	
	X, Y, Z directions (30min.)	
Noise Immunity (via noise emulator)	Noise Voltage: 1,500Vp-p	Noise Voltage: 1,000Vp-p
	Pulse Duration: 1ms, 500ns, 50ns Rise Time: 1ns	Pulse Duration: 1ms, 500ns, 50ns Rise Time: 1ns
Electrostatic Discharge Immunity	4kV (complies with EN 61000-4-2)	

**1 When using a FP-2600 Series unit in an environment where the temperature reaches or exceeds 40 °C for an extended period of time, the screen contrast level may decrease from its original level.*

2.1.3 Structural

Grounding	100Ω or less, or your country's applicable standard
Ratings ^{*1} (For front panel of installed unit)	Equivalent to IP65f (JEM 1030)
External Dimensions	W317mm [12.48 in] x H243mm [9.57 in] x D58mm [2.28 in]
Weight	3.5kg (7.7lb) or less
Cooling Method	Natural air circulation

**1 The front face of the FP unit, installed in a solid panel, has been tested using conditions equivalent to the standard shown in the specification. Even though the FP unit's level of resistance is equivalent to the standard, oils that should have no effect on the FP can possibly harm the unit. This can occur in areas where either vaporized oils are present, or where low viscosity cutting oils are allowed to adhere to the unit for long periods of time. If the FP's front face protection sheet peels off, these conditions can lead to the ingress of oil into the FP and separate protection measures are suggested. Also, if non-approved oils are present, it may cause deformation or corrosion of the front panel's plastic cover. Therefore, prior to installing the FP be sure to confirm the type of conditions that will be present in the FP's operating environment.*

If the installation gasket is used for a long period of time, or if the unit and its gasket are removed from the panel, the original level of the protection cannot be guaranteed. To maintain the original protection level, be sure to replace the installation gasket regularly.

2.2 Functional Specifications

2.2.1 Performance

		FP-2500 Series	FP-2600 Series
Graphics		VGA (640 X 480)	SVGA (800 X 600)
Display Unit		10.4 inch TFT VGA	12.1 inch TFT SVGA
Touch Panel I/F	Type	Resistive Film (Analog)	
	Resolution	1024 X 1024	
	Interface	Serial Interface (RS-232C) USB Interface	
Video I/F		Analog RGB Interface DVI-D Interface	

2.2.2 Display

	FP-2500 Series	FP-2600 Series
Type	TFT Active Matrix Color LCD	
Resolution	640 (H) X 480 (V) pixels	800 (H) X 600 (V) pixels
Dot Pitch	0.330mm [0.01in.] (H) X 0.330mm [0.01in.] (V)	0.3075mm [0.01in.] (H) X 0.3075mm [0.01in.] (V)
Display colors	260,000 colors (R/G/B six bits each)	
Brightness Control	Available	
Contrast Control	Available (Analog RGB only) (when using analog RGB connection)	
Display area*¹	211.2mm [8.31in.] (W) X 158.4mm [6.24 in.] (H)	246.0mm [9.69in.] (W) X 184.5mm [7.26in.] (H)
Display Modes*²	640X350, 640X400, 640X480, 720X350, 720X400	640X350, 640X400, 640X480, 720X350, 720X400, 800X600
Backlight	CCFL (Replaceable)	
Backlight Lifetime	Backlight can be replaced by the user. 50,000 hours at an ambient temperature of 25°C ³	

*1 Setting up OSD. For details, refer to 4.2 Screen Display Adjustment

*2 For details, refer to 2.3 Interface Specifications

*3 50% decreased brightness indicates the backlight needs to be replaced. This value is only for reference and not a guaranteed value.

2.3 Interface Specifications

2.3 Interface Specifications

2.3.1 Analog RGB Interface

Input signal type	Analog RGB
Input signal characteristic	Image signal: analog RGB Synchronous signal: TTL level, negative true or positive true Scanning type: non-interlaced
Setting via OSD (On Screen Display)	CONTRAST BRIGHTNESS H-POS V-POS H-SIZE PHASE BACKLIGHT DEFAULT (ALL CLEAR)

The number of dots (pixels) displayed are as follows:

◆FP-2500 Series

Resolution	H Sync. (kHz)	V Sync (Hz)	Dot Clock (MHz)	Screen Resolution Expansion (H : Horizontal) (V : Vertical)	Display Resolution
640×350 ^{*1}	31.469	70.000	25.175	×1.0(H) ×1.2(V)	640×420
640×400	31.469	70.000	25.175		640×480
640×400	24.827	56.420	21.053		640×480
640×480	31.469	59.992	25.175	×1.0	640×480
720×350 ^{*1,2,3}	31.469	70.000	28.320	×1.0(H)	640×420
720×400 ^{*2,3}	31.469	70.000	28.320	×1.2(V)	640×480

*1 When the 350 pixel (vertical) signal setting is selected, 400 pixels, including 50 pixels at the top and at the bottom of the screen, will be enlarged and displayed at 480 pixels (1.2times).

*2 Select "720 x 400 Display Resolution 720 x 400 DSP" in the OSD (On Screen Display) "System Setting" screen.

*3 When the 720 pixel (horizontal) signal setting is selected,

- When "720 x 400 DSP" is ON; only 640 pixels are displayed (80 pixels are not displayed.)
- When "720 x 400 DSP" is OFF; all pixels are displayed but images may be partially cut off.

2.3 Interface Specifications

◆FP-2600 Series

Resolution	H Sync. (kHz)	V Sync (Hz)	Dot Clock (MHz)	Screen Resolution Expansion (H : Horizontal) (V : Vertical)	Display Resolution
640×350 ^{*1}	31.469	70.000	25.175	×1.25(H) ×1.5(V)	800×525
640×400	31.469	70.000	25.175		800×600
640×400	24.827	56.420	21.053		800×600
640×480	31.469	59.992	25.175	×1.25(H) ×1.25(V)	800×600
640×480	35.000	66.670	30.240		800×600
640×480	37.861	72.810	31.500		800×600
720×350 ^{*1*2}	31.469	70.000	28.320	×1.0(H) ×1.5(V)	720×525
720×400 ^{*2}	31.469	70.000	28.320		720×600
800×600	35.156	56.250	36.000	×1.0	800×600
800×600	37.879	60.317	40.000		800×600

**1 When the 350 pixel (vertical) signal setting is selected, 400 pixels, including 50 pixels at the top and at the bottom of the screen will be enlarged and displayed at 600 pixels (1.5times).*

**2 Select "720 x 400 Display Resolution 720 x 400 DSP" in the OSD (On Screen Display) "System Setting" screen.*

2.3 Interface Specifications

■ Analog RGB Interface

Pin Assignments and Signal Names

Pin No.	Signal Name	Condition	Pin Location
1	Analog R	R signal input	
2	Analog G	G signal input	
3	Analog B	B signal input	
4	Reserved	NC (spare for input)	
5	Digital grounding	Digital signal GND	
6	Return R	R signal GND	
7	Return G	G signal GND	
8	Return B	B signal GND	
9	Reserved	NC (spare for input)	
10	Digital grounding	Digital signal GND	
11	Reserved	NC (spare for input)	
12	Reserved	NC (spare for input)	
13	H. SYNC	Horizontal synchronous signal input	
14	V. SYNC	Vertical synchronous signal input	
15	Reserved	NC (spare for input)	

Connector: Mini Dsub 15 pin male

Connector set screw: Inch type (4-40)

Analog RGB Cable: FP-CV00<2.5m>,FP-CV01<5m>,FP-CV02-45<4.5m>manufactured by Digital Electronics Corporation of Japan



If a cable other than the specified RGB cable is used, FP unit operation cannot be guaranteed due to the possibility of noise interference.

2.3 Interface Specifications

2.3.2 DVI-D Interface

Input signal type	DVI-D
Setting by OSD (On Screen Display)	H-POS V-POS BACKLIGHT DEFAULT (ALL CLEAR)

The number of dots (pixels) displayed are as follows:

◆ FP-2500 Series

Resolution	H Sync. (kHz)	V Sync (Hz)	Dot Clock (MHz)	Screen Resolution Expansion (H : Horizontal) (V : Vertical)	Display Resolution
640×400	31.469	70.000	25.175	×1.0(H)	640×480
640×400	24.827	56.420	21.053	×1.2(V)	640×480
640×480	31.469	59.992	25.175	×1.0	640×480
720×400 ^{*1}	31.469	70.000	28.320	×1.0(H) ×1.2(V)	640×480

*1 When the horizontal 720 pixel signal is input;

-VGA Graphic & Text mode displays 640 pixels only and 80 pixels are not displayed.

◆ FP-2600 Series

Resolution	H Sync. (kHz)	V Sync (Hz)	Dot Clock (MHz)	Screen Resolution Expansion (H : Horizontal) (V : Vertical)	Display Resolution
640×400	31.469	70.000	25.175	×1.25(H)	800×600
640×400	24.827	56.420	21.053	×1.5(V)	800×600
640×480	31.469	59.992	25.175	×1.25(H)	800×600
640×480	35.000	66.670	30.240	×1.25(V)	800×600
640×480	37.861	72.810	31.500	×1.25(V)	800×600
720×400 ^{*1}	31.469	70.000	28.320	×1.0(H) ×1.5(V)	720×600
800×600	35.156	56.250	36.000	×1.0	800×600
800×600	37.879	60.317	40.000	×1.0	800×600

*1 When you use this resolution, select "720 x 400 Display Resolution 720 x 400 DSP" in "System Setting" of the OSD (On Screen Display) .

2.3 Interface Specifications

■ DVI-D Interface

Pin Assignments and Signal Names

Pin No.	Signal Name	Pin No.	Signal Name	Pin Location
1	TMDS DATA2-	13	NC	
2	TMDS DATA2+	14	NC	
3	TMDS DATA2/4 SHIELD	15	GND (+5V)	
4	NC	16	Hot Plug Detect	
5	NC	17	TMDS DATA0-	
6	DDC Clock	18	TMDS DATA0+	
7	DDC Data	19	TMDS DATA0/5 SHIELD	
8	NC	20	NC	
9	TMDS DATA1-	21	NC	
10	TMDS DATA1+	22	TMDS CLOCK SHIELD	
11	TMDS DATA1/3 SHIELD	23	TMDS CLOCK+	
12	NC	24	TMDS CLOCK-	

Connector: DVI-D 24-pin male

Connector set screw: Inch type (4-40)

DVI-D Cable: FP-DV01-50 <5 m> manufactured by Digital Electronics Corporation



- *If a cable other than the specified DVI-D cable is used, FP unit operation cannot be guaranteed due to the possibility of noise interference.*

2.3.3 RS-232C Interface

RS-232C Interface	Baud rate: 9600 bps Data length: 8 bits Parity: none Stop bit: 1
-------------------	---------------------------------------------------------------------------

■ RS-232C Interface

Pin Assignments and Signal Names

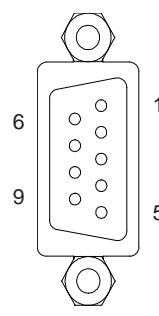
Pin No.	Signal Name	Condition	Pin Location
1	CD	Carrier Detect ^{*1}	
2	RD	Receive Data (FP->Host)	
3	SD	Send Data (FP<-Host)	
4	DTR	Data Terminal Ready ^{*1}	
5	GND	Ground	
6	DSR	Data Set Ready ^{*1}	
7	RS	Request to Send (FP<-Host)	
8	CS	Clear to Send (FP->Host)	
9	NC	(Used internally)	

Connector: Dsub 9 pin female

Connector set screw: Inch type (4-40)

RS-232C Cable: FP61V-IS00-O <5m> manufactured by Digital Electronics Corporation of Japan

**1 CD, DTR, and DSR are connected together inside the FP.*



Note: Signal Names

Signal names used for the RS-232C Interface are designed to match the pin order used on most PC RS-232C interfaces, which allows a straight cable to be used to connect the two. Therefore, connect each pin's signal to the same signal name on the PC side.

For example, the FP unit connector's pin #2 'RD' should be connected to the PC connector's 'RD' terminal. For detailed signal direction information,

Reference 2.4 Cable Diagrams



If a cable other than the specified RS-232C cable is used, FP unit operation cannot be guaranteed due to the possibility of noise interference.

2.3 Interface Specifications

2.3.4 USB Interface

■ USB Interface

Pin Assignments and Signal Names

Pin NO.	Signal Name	Condition	Pin Location
1	USB1-5V	+5VIN	
2	USBD1(-)	USB data(-)	
3	USBD1(+)	USB data(+)	
4	GND	Ground	

Communication: Low speed Device

Connector : B type connector

USB Cable : FP-US00 <5m> manufactured by Digital Electronics Corporation



If a cable other than the specified USB cable is used, FP unit operation cannot be guaranteed due to the possibility of noise interference.

2.4 Cable Diagrams

2.4.1 Analog RGB Interface Pin Connections (Optional cable)

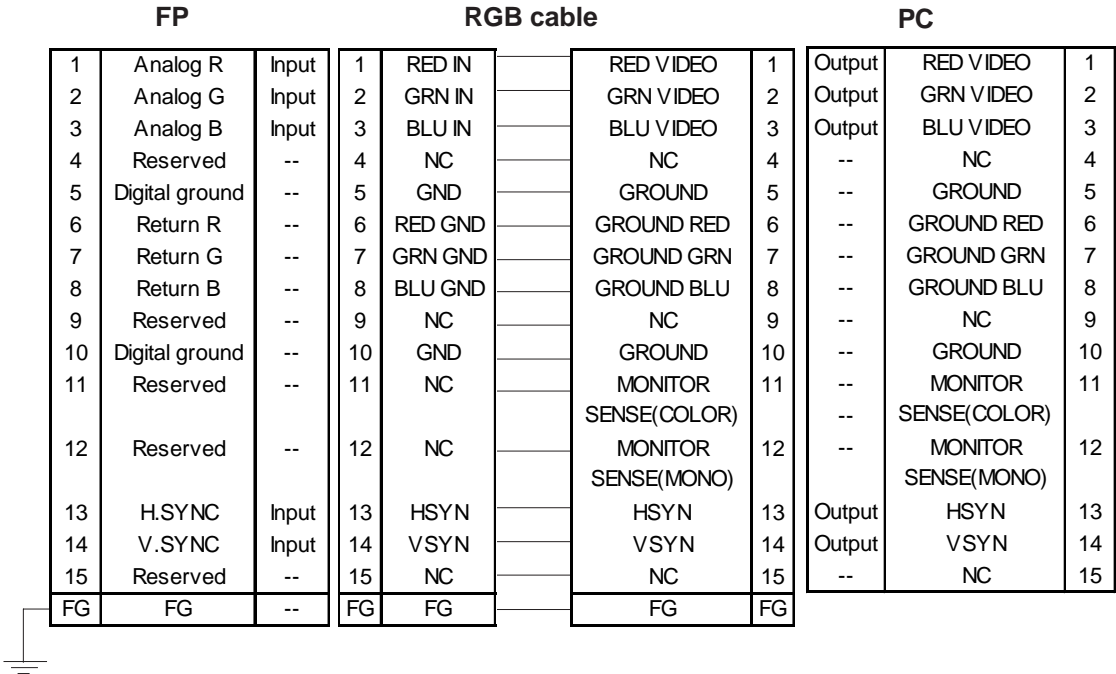

Signals and signal names used with the FP and the Analog RGB cable (optional cable) are the same as those used for PCs. Also, the same pin is used on both sides of the optional cable so that you can connect the cable regardless of the cable direction.

Inch is used for the pitch of the connector screw on the PC. For this reason, inch (4-40) is also used for the pitch of the connector screw for the cable and the FP.

2.4 Cable Diagrams

2.4.2 DVI-D Interface Pin Connections (Optional cable)

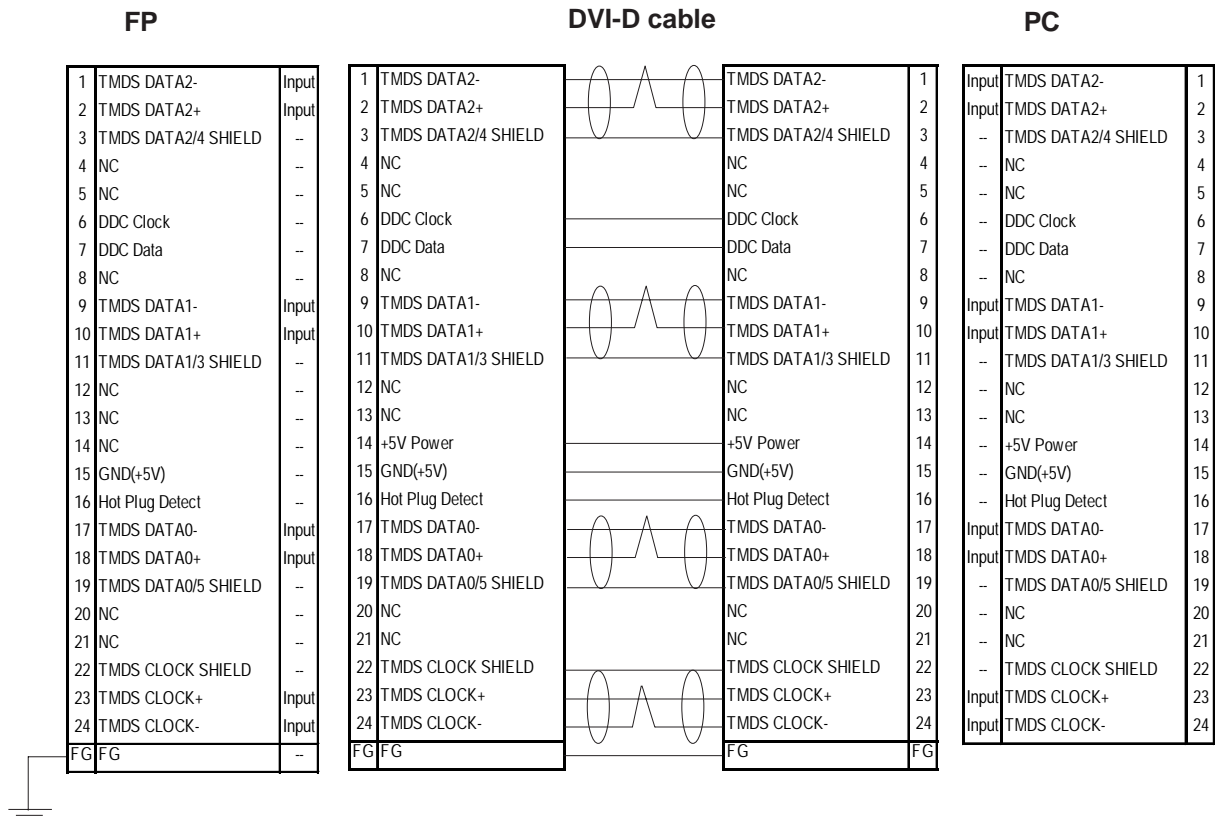

Signals and signal names used with the FP and the DVI-D cable (optional cable) are the same as those used for the PC. Also, the same pin is used on both sides of the optional cable so that you can use the cable without worrying about the cable's direction.

Inch is used for the pitch of the connector screw on the PC. For this reason, inch (4-40) is also used for the pitch of the connector screw for the cable and the FP.

2.4 Cable Diagrams

2.4.3 RS-232C Interface Pin Connections (Optional cable)

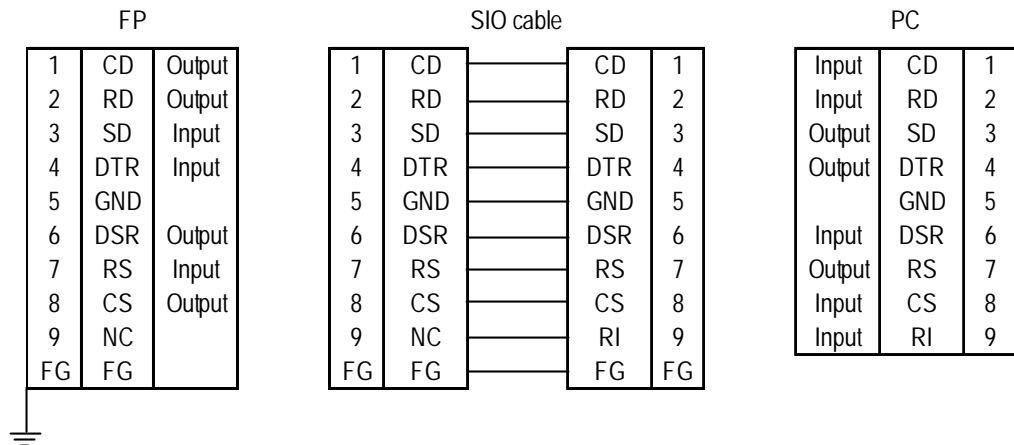

Signals and signal names used with the FP and the RS-232C cable (optional cable) are the same as those used for PCs. Also, the same pin is used on both sides of the optional cable so that you can connect the cable regardless of the cable direction.

Inch is used for the pitch of the connector screw on the PC. For this reason, inch (4-40) is also used for the pitch of the connector screw for the cable and the FP.

2.4.4 USB Interface Cable Pin Connections (Option cable)

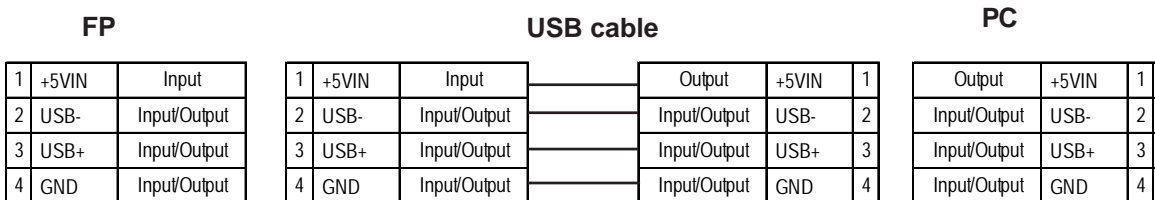

2.5 Names and Functions of FP Parts

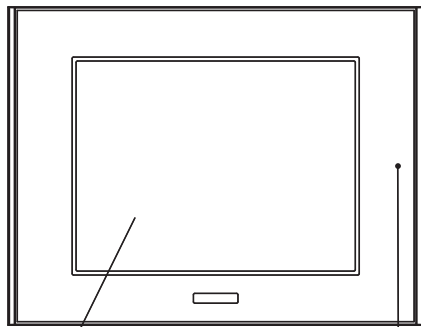

FP-2500 Series Front

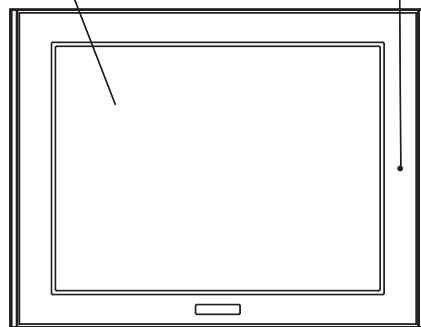

FP-2600 Series Front

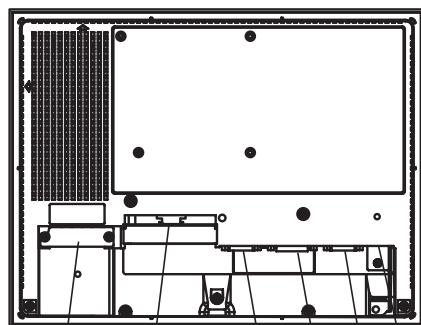

Rear

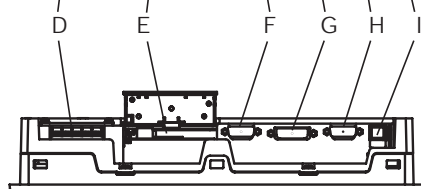

Bottom

A : TFT Color LCD

Displays host data.

B : Touch Panel

Switches screens or writes/sends data to the host.

C : Front LED

Used to indicate status of power supply, backlight or image signal input.

Reference 3.3.2 Status of Front LED in Operation Modes

D : Power Input Terminal Block

Provides power to the FP unit via the input and ground terminals

E : Dip Switches

Switches for setting up the FP unit's Operation Mode.

G : Analog RGB Connector

Connector for analog RGB cable.

H : DVI-D Interface Connector

Connector for DVI-D cable.

I : RS-232C Connector

Connector for RS-232C (serial) interface. Used sending touch panel data to the host, and receiving commands from the host.

J : USB Connector

Connector for USB cable. Used for sending touch panel data to the host, and receiving commands from the host.

2.6 FP Dimensions

2.6.1 External Dimensions

◆FP-2500 Series

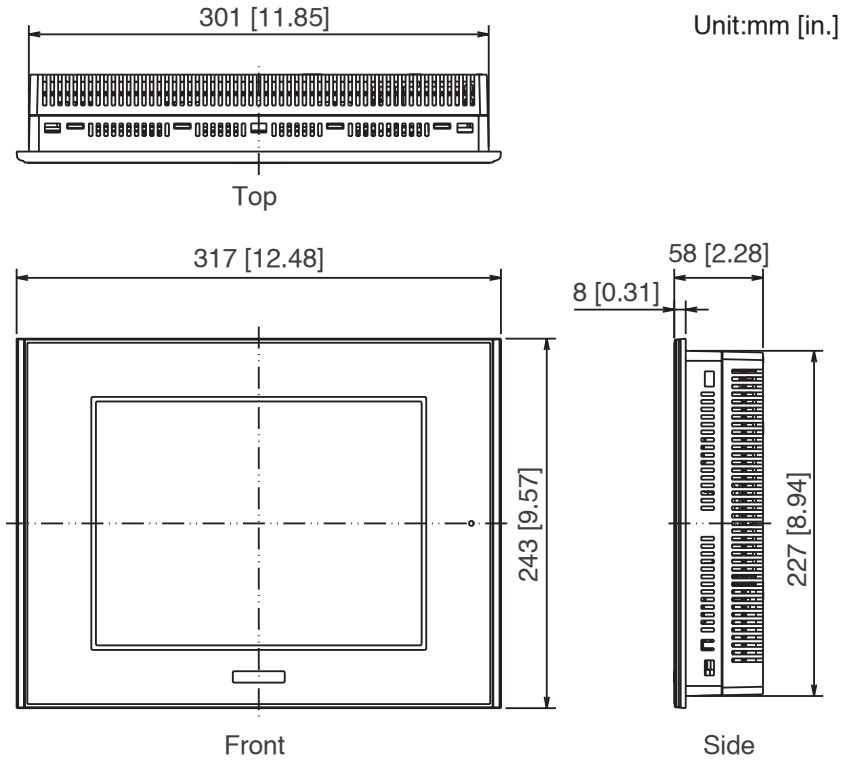

◆FP-2600 Series

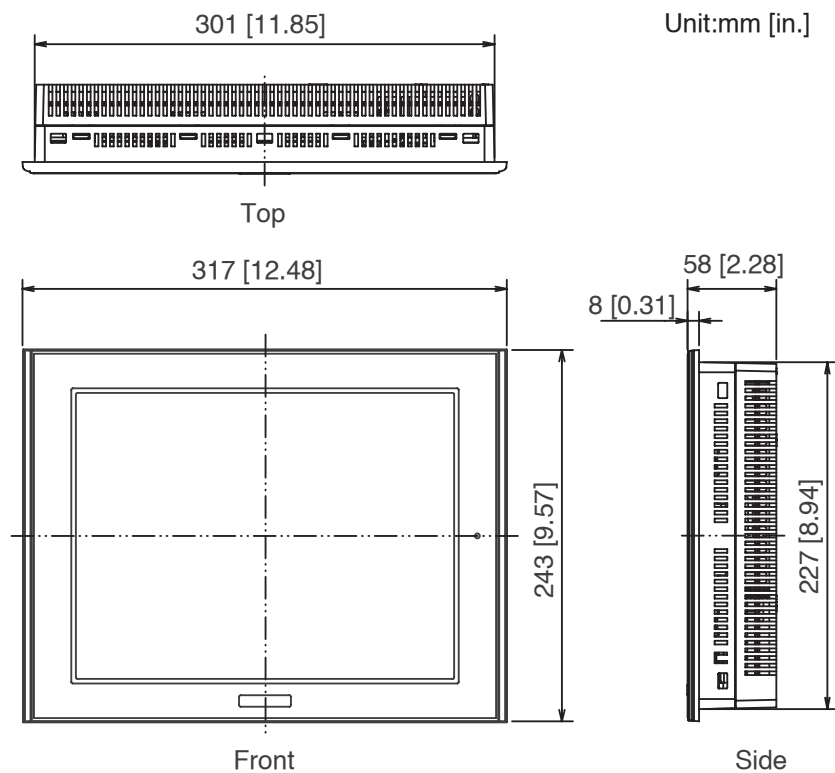

2.6 FP Dimensions

2.6.2 External Dimensions (with Installation Fasteners)

◆FP-2500 Series

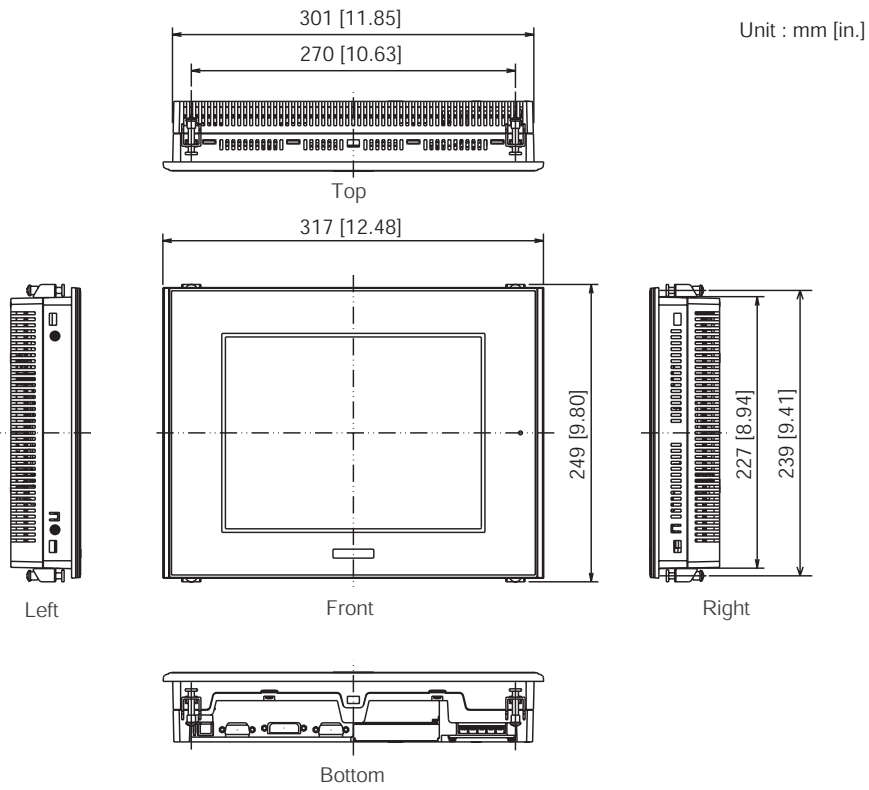

◆FP-2600 Series

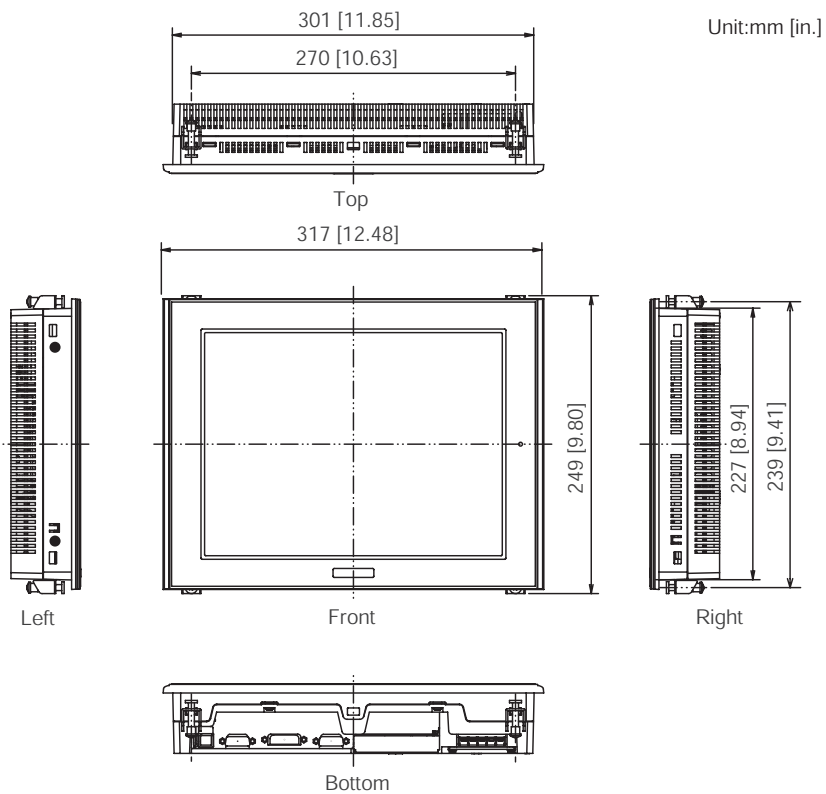

2.6.3 Installation Fasteners

Unit : mm [in.]

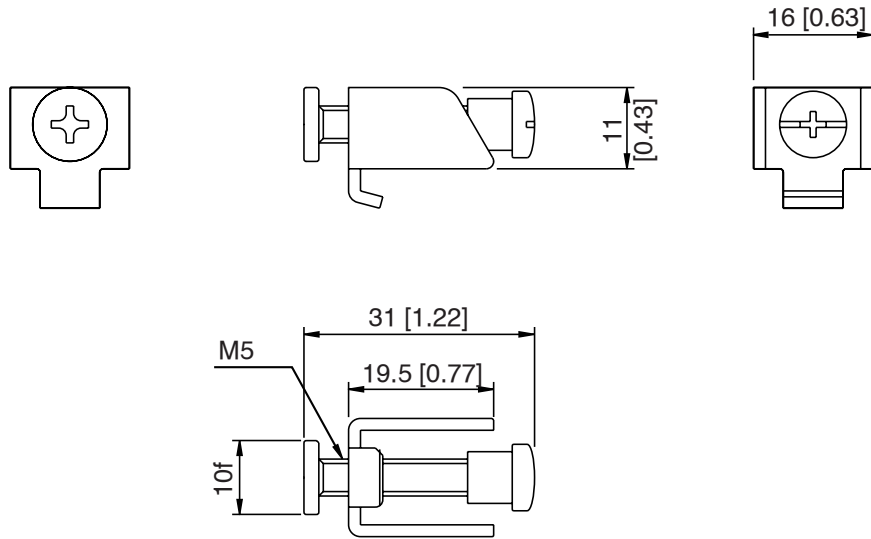

2.6.4 FP Panel Cut Dimensions

Unit: mm [in.]

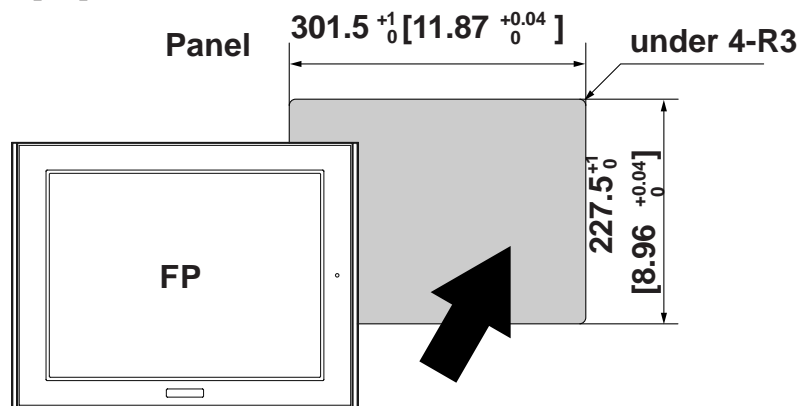

- Panel thickness should be between 1.6mm [0.06in.] and 10.0mm [0.4in.]. Panel's thickness should be based on the level of panel strength required.
- Check that the installation panel or cabinet's surface is flat, in good condition and has no jagged edges.
- If desired, metal reinforcing strips can be attached to the inside of the panel, near the Panel Cut, to increase the panel's strength.

▼ **Reference** ▲ *3.1.1 Installation Procedure*

- Be sure to create the correct sized panel cut required to install the FP, using the installation dimensions given.

Memo

Chapter 3

Installation and Wiring

1. Installation
2. Wiring
3. Operation Mode Setup and Display Positioning

3.1 Installation

3.1.1 Installation Procedures

Follow the steps given below when installing the FP.

■ Check the Installation Gasket's Seating

It is strongly recommended that you use the installation gasket, since it absorbs vibration in addition to repelling water.

Place the FP on a level surface with the display panel facing downward. Check that the FP unit's installation gasket is seated securely into the gasket's groove, which runs around the perimeter of the panel's frame.

For details about installing the gasket, refer to

Reference 6.1.2 *Installation Gasket Check/Replacement*



- **Before installing the FP into a cabinet or panel, check that the installation gasket is securely attached to the unit.**
- **A gasket which has been used for a long period of time may have scratches or dirt on it, and can lose much of its dust and drip resistance. Be sure to change the gasket periodically (or when scratches or dirt become visible).**
- **Be sure to use gasket model GP570-WP10-MS.**
- **Be sure the gasket's seam is not inserted into any of the unit's corners, only in the straight sections of the groove. Inserting it into a corner may lead to its eventually tearing.**
- **To ensure the installation gasket's maximum level of moisture resistance, be sure the gasket's seam is inserted as shown into the panel's bottom face.**

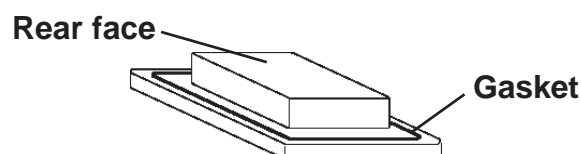

3.1 Installation

■ Creating a Panel Cut

Create the correct sized opening required to install the FP, using the installation dimensions given.

▼ **Reference** 2.6.4 FP Installation Dimensions

The installation gasket, installation fasteners and attachment screws are all required when installing the FP.

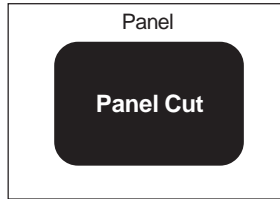

- **Check that the installation panel or cabinet's surface is flat, in good condition and has no jagged edges. Also, if desired, metal reinforcing strips can be attached to the inside of the panel, near the Panel Cut, to increase the panel's strength.**
- **Panel thickness should be from 1.6mm [0.06in.] to 10.0mm [0.4in.]. Decide the panel's thickness based on the level of panel strength required.**

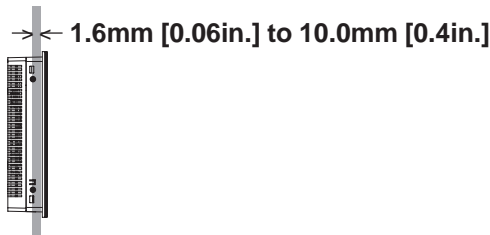

For easier maintenance, operation, and improved ventilation, be sure to install the FP at least 100 mm [3.94 in.] away from adjacent structures and other equipment.

Unit: mm [in.]

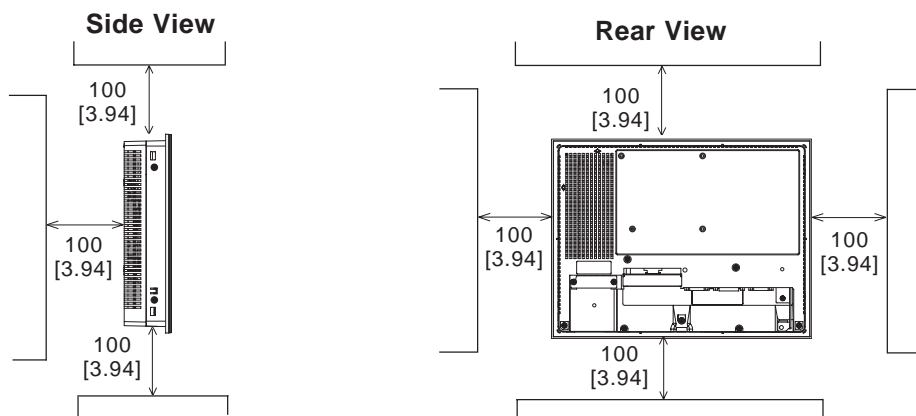



- **Be sure that the ambient temperature and the ambient humidity are within their designated ranges. (When installing the FP in a cabinet or enclosure, the term “ambient temperature” indicates the cabinet or enclosure’s internal temperature.)**

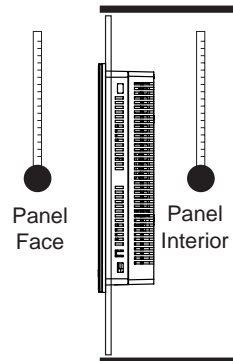

- **Be sure that heat from surrounding equipment does not cause the FP to exceed its standard operating temperature.**
- **When installing the FP in a slanted panel, the panel face should not incline more than 30°.**

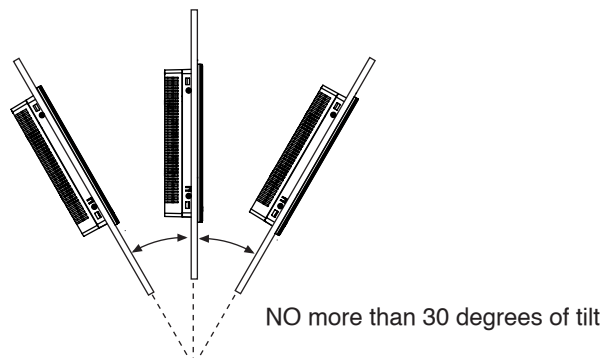

- **When installing the FP in a slanted panel, and the panel face inclines more than 30°, the ambient temperature must not exceed 40 °C. You may need to use forced air cooling (fan, A/C) to ensure the ambient operating temperature is 40 °C or below.**

3.1 Installation

■ Installing the FP

- 1) Insert the FP into the panel cut, as shown here.

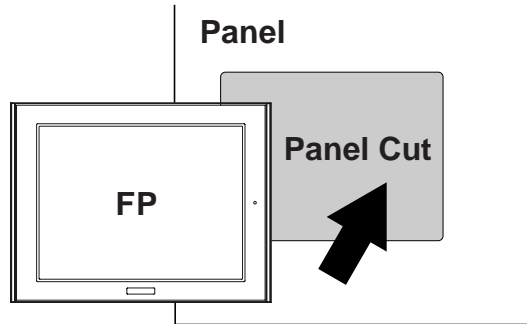

- 2) Insert the installation fasteners into the FP unit's insertion slots, at the top and bottom of the unit. (total:4 slots)

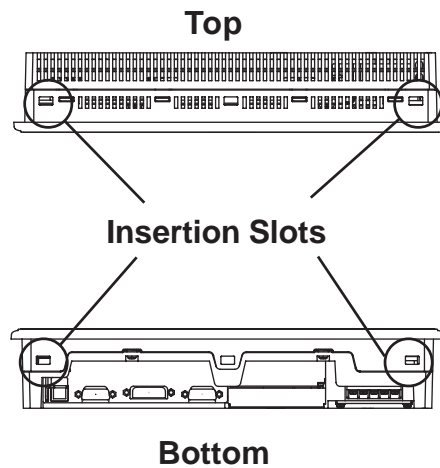

- 3) Insert each of the fasteners as shown right. Be sure to pull the fastener back until it is flush with the rear of the attachment hole.

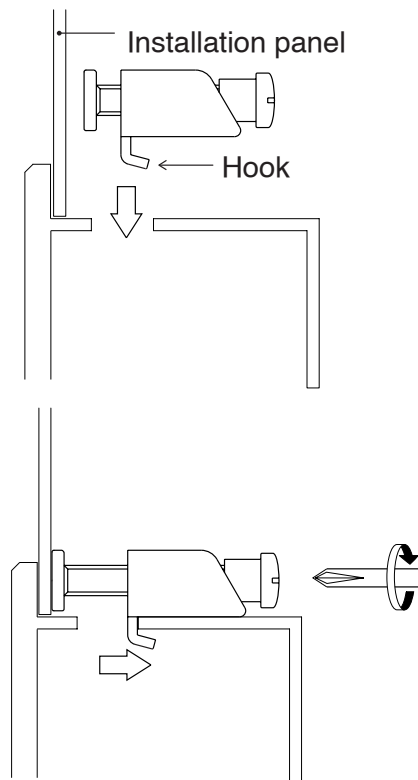

3.1 Installation

- 4) Use a Phillips screw driver to tighten each fastener screw and secure the FP in place.

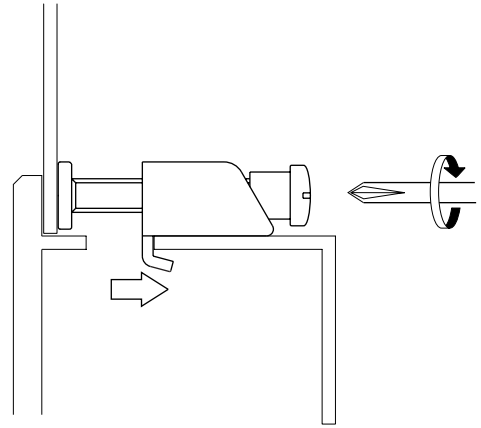

Do not use too much force, since it may damage the FP unit. A torque of only 0.5 N•m is sufficient to tighten these screws.



- Depending on the panel condition, you can improve moisture resistant effect by increasing the number of installation fasteners.
- Installation fasteners are sold by your local FP distributor.

3.2 Wiring Cautions

3.2.1 Connecting the Power Cord



WARNINGS

- To avoid an electric shock, when connecting the FP unit's power cord terminals to the power terminal block, confirm that the power supply is completely turned OFF, via a breaker, or similar unit.
- FP2500-T12 and FP2600-T12 units are designed to use only AC100V to AC240V input. FP2500-T42-24V and FP2600-T42-24V units are designed to use only DC24V input. Any other power level can damage both the FP and the power supply.
- Since there is no power switch on the FP unit, be sure to attach a breaker-type switch to its power cord.
- Be sure to ground the FP's FG terminal. Failure to do so can lead to an electrical shock or FP malfunction.



- *To prevent the Ring Terminals from causing a short when the terminal block attachment screws are loosened, be sure to use sleeve-type Ring Terminals.*
- *When the FG terminal is connected, be sure the wire is grounded. Not grounding the FP unit will result in excessive noise. Use your country's applicable standard for grounding.*

Reference 3.2.3 Grounding

- *The SG and FG terminals are connected internally in the FP unit.*
- *When connecting the SG line to another device, be sure that the design of the system/connection does not produce a shorting loop.*



- Wherever possible, use thick wires (max 2mm²) for power terminals, and twist the exposed wire ends when connecting the Ring Terminals.
- Please use the following size crimp-on type Ring Terminals.

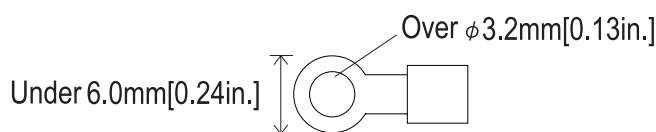

■ Connecting the Power Supply Terminals

◆ FP2500-T12/FP2600-T12

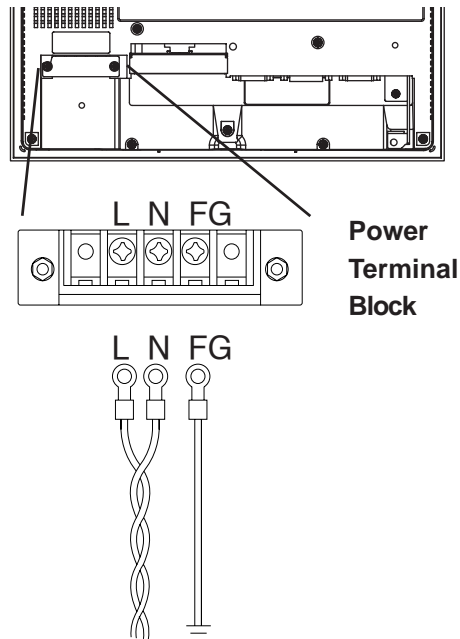

L	AC Input Live Line
N	AC Input Neutral Line
FG	Grounding Terminal connected to the FP chassis.

◆ FP2500-T42-24V/FP2600-T42-24V

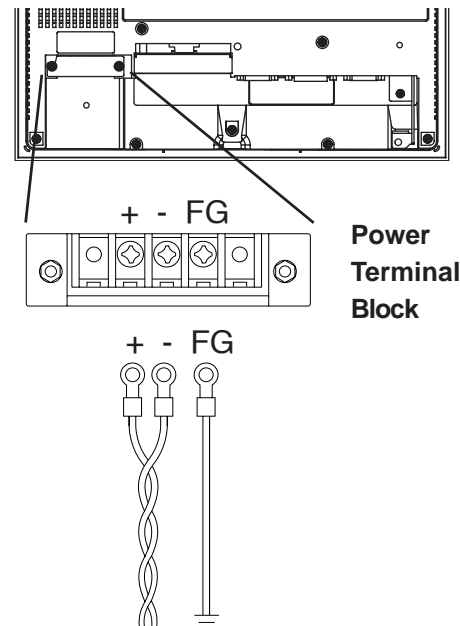

+	Positive electrode
-	Negative electrode
FG	Grounding Terminal connected to the FP chassis.

- 1) Confirm that the FP unit's Power Cord is unplugged from the power supply.
- 2) Use a screwdriver to remove the Power Input Terminal Block's clear plastic cover.
- 3) Unscrew the screws from the middle three (3) terminals, align the Ring Terminals and reattach the screws.



- Confirm that the ring terminal wires are connected correctly.
- A torque of only 0.5 to 0.6 N•m is required to tighten an attachment screw.

- 4) Replace the Power Input Terminal Block's clear plastic cover.

3.2 Wiring

3.2.2 Connecting the USB Cable Strap Attachment

◆ USB Cable Strap Attachment Procedure

- 1) Insert the USB cable into the USB connector.
- 2) Tighten the strap until the cable is secured in place and insert the cable strap into the cable strap holder as shown in the following figure.

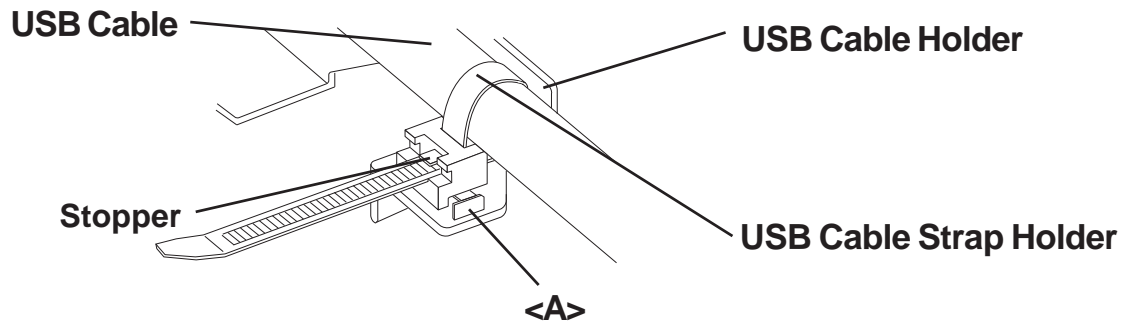

◆ USB Cable Strap Removal Feature

- 1) Push in the cable strap's stopper with a standard flat-blade screwdriver until the cable strap band is unlocked, and remove the strap.
- 2) Disconnect the USB cable.



Note:

- If the stopper will not move, press on <A> (shown in figure) to free the strap from the strap holder.

3.2.3 Connecting the Power Supply

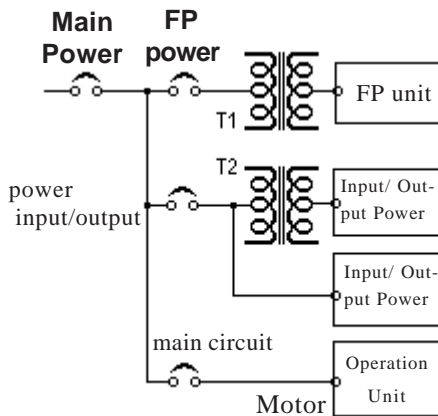
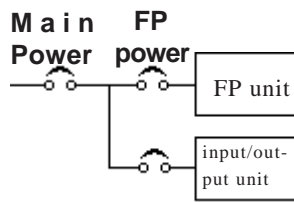

- When supplying power to the FP unit, be sure to separate the input/output and operation unit lines, as shown.
- To increase the noise resistance quality of the power cable, be sure to twist each power wire before attaching the Ring Terminal.
- The power supply cable must not be bundled or positioned close to main circuit lines (high voltage, high current), or input/output signal lines.
- Connect a lightning surge absorber, as shown in the diagram, to deal with power surges.
- To avoid excess noise, make the power cable as short as possible.

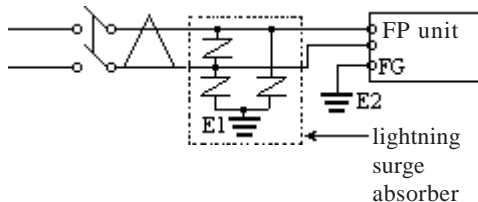

- **Be sure to ground the surge absorber (E1) separately from the FP unit (E2).**
- **Select a surge absorber that has a maximum circuit voltage greater than the power supply's peak voltage.**

3.2 Wiring

3.2.4 Precautions: Grounding

(a) Exclusive grounding (BEST)

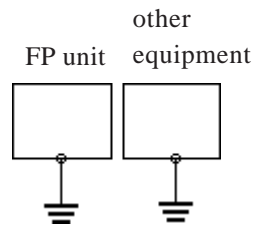

(b) Common grounding (OK)

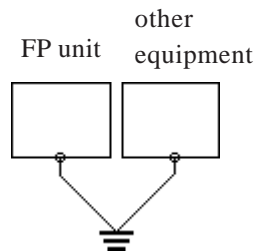

(c) Common grounding (BAD)

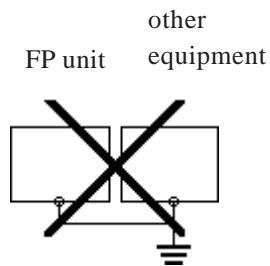

- Connect the FP unit's FG terminal to an exclusive ground. [diagram (a) - Grounding resistance of under 100Ω.]
- If exclusive grounding is not possible, use a common connection point. [diagram (b)]
- The grounding wire should have a cross sectional area greater than 2mm². Make the connection point as close to the FP unit as possible, and make the wire as short as possible. When using a long grounding wire, replace the thin wire with a thicker wire placed in a duct.
- If this equipment does not function properly when grounded, disconnect the ground wire from the FG terminal.

3.2.5 Precautions: Input/Output Signal Lines

- Input and output signal lines must be separated from operating circuit power cables. If this is not possible, use a shielded cable and connect the shield to the FP chassis.

Chapter 4

- 1. Operation Mode Setup
- 2. Screen Display Adjustment

Setting up and Adjusting the FP unit

4.1 Operation Mode Setup

4.1.1 Dip Switch Preset Settings and Adjustments

The FP unit's dip switches are located behind the Dip Switch Cover.

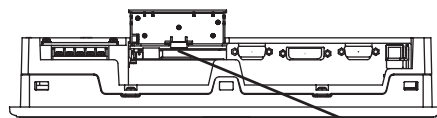

Dip Switches

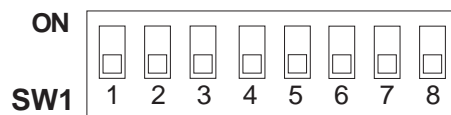

SW No.	Function	Description	Factory Settings
1-1	Switch between USB and RS-232C for touch panel data transmission.	Used to set the touch panel data input (command control) method to either USB or RS-232C. ON : USB OFF : RS-232C (Default setting)	All OFF
1-2	Display/hide the OSD.	Used to display or hide the OSD. ON : Hide OFF : Display (Default setting)	
1-3	Reserved	Set this switch to OFF	
1-4			
1-5	Switch between analog RGB and DVI-D input.	Used to change the image input method. ON : DVI-D OFF : analog RGB (Default setting)	
1-6	Reserved	Be sure these switches are always set to OFF	
1-7			
1-8			



Note: Dip switch settings are effective only when starting up the FP unit. After changing any dip switch settings, be sure to restart your FP unit.

4.1 IOperation Mode Setup

4.1.2 Status of Front LED in Operation Modes

LED	OFF (Not Lit)	Green	Orange	Green/ Red Flash	Orange Flash
Panel	Power OFF	Power ON	Power ON	Power ON	Power ON
Backlight	-	Normal	Normal	Burned-out	Burned-out
Image Input	-	Yes	No	Yes	No

4.2 Screen Display Adjustment

4.2.1 Calibration of OSD Display Position

Simply touch the touch panel to call up the OSD (On Screen Display) screen. This screen allows you to perform detailed display adjustment.

■ Starting the OSD

To start the OSD and enter OSD mode, press the three corners of the touch panel in the following order ((1) upper left, (2) upper right and (3) lower right) within 5 seconds. In OSD mode, the setting screen is displayed in the center of the screen and the touch panel cannot be used to communicate with external devices until the OSD setup is completed.

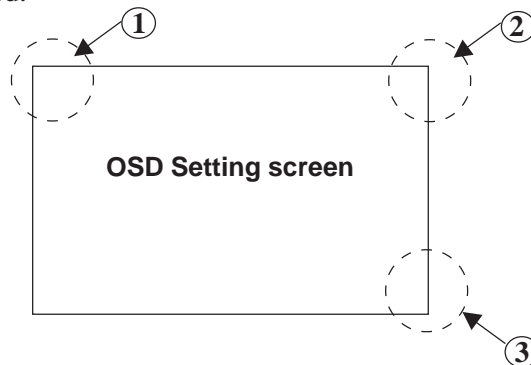

Note: OSD is not displayed when DIP SW 1-2 is ON.

■ Using the OSD

The setting screen uses icons to (select and) enter settings. When you start up the OSD, the main menu appears. Touching an icon displays its submenu or setting change screen. In the setting screen, ◀ and ▶ icons are used to change the setting. To apply the setting, press the **SET** button. Press the **SAVE** button to save the defined settings.

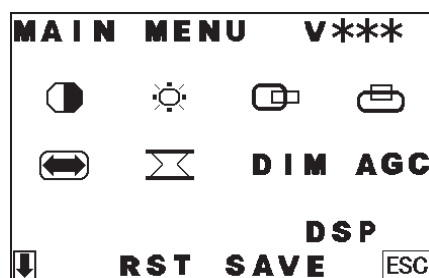









"V***" indicates the OSD version.

4.2 Screen Display Adjustment

■ Quitting the OSD

To quit the OSD, press the **ESC** button in the main menu or leave the OSD as it is for at least 30 seconds. If the OSD is automatically closed after 30 seconds of inactivity, the values set before the OSD was closed will be applied.

4.2.2 OSD Setting Icons

Item		Function
	CONTRAST	Adjusts the contrast. (Analog RGB only) ^{*1}
	BLACK LEVEL	Adjusts the color brightness. (Analog RGB only) ^{*1}
	H-POS	Adjusts the horizontal position of the screen.
	V-POS	Adjusts the vertical position of the screen.
	H-SIZE	Adjusts the screen size in the horizontal direction. (Analog RGB only) ^{*1}
	PHASE	Adjusts the input signal and the dot clock position. (32 levels) (Analog RGB only) ^{*1}
DIM	BACKLIGHT	Adjusts the backlight brightness. (9 levels)
AGC	AUTO GAIN CONTROL	Automatically adjusts the contrast and the brightness. (Analog RGB only) ^{*1}
DSP	DISPLAY MODE	Displays the resolution of the input image data.
RST	OSD CLEAR (RESET)	Resets the current OSD value to the default value.
SAVE	OSD SAVE	Save the current value and quit the OSD.
	SYSTEM	Changes settings such as activating the click sound.
	ESCAPE	Cancels the setting and returns to the upper level. In the main menu, this command closes the OSD.

**1 When using DVI-D, the message "DO NOT NEED SETUP FOR DVI-D" is displayed and no settings are required.*

4.2 Screen Display Adjustment

4.2.3 OSD Setting Item Details

■ Main menu

CONTRAST

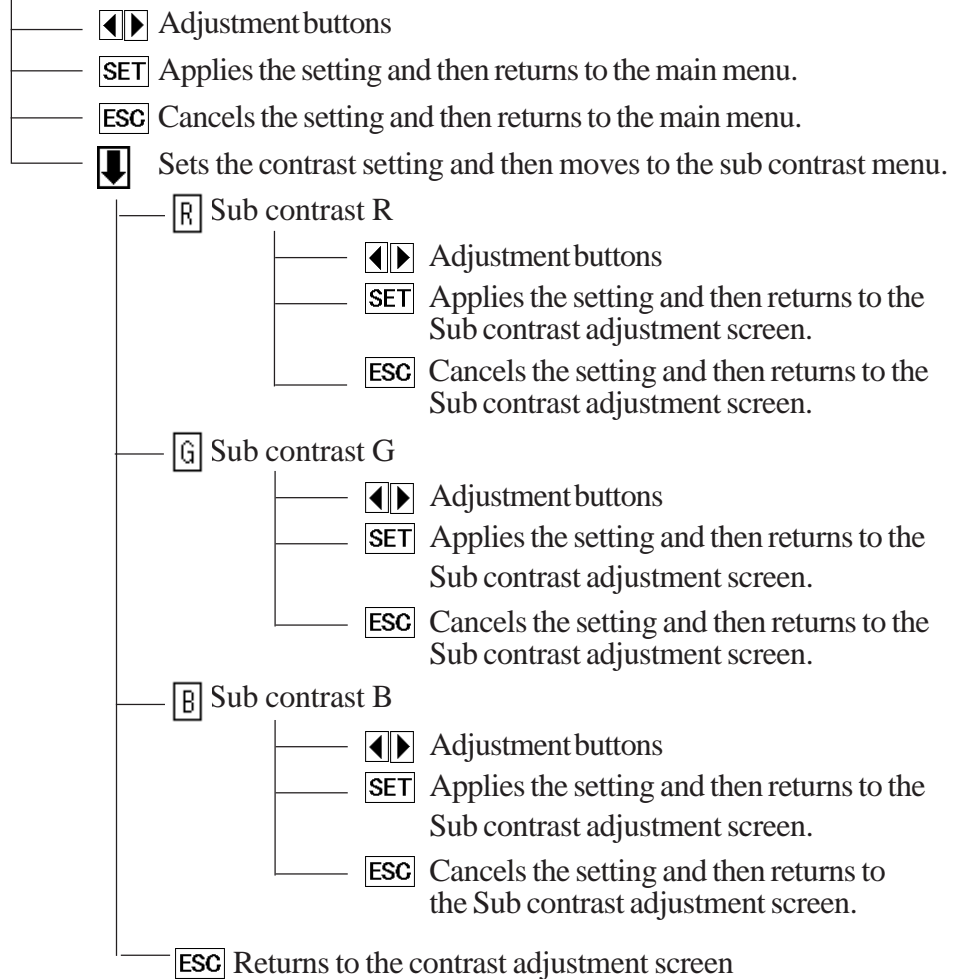

BLACK LEVEL

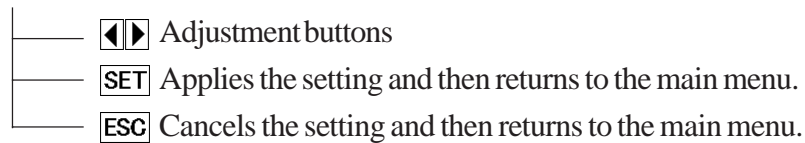

H-POS

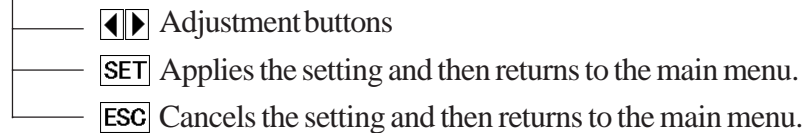

V-POS

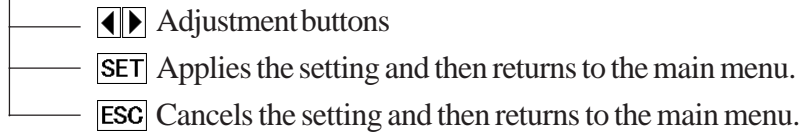

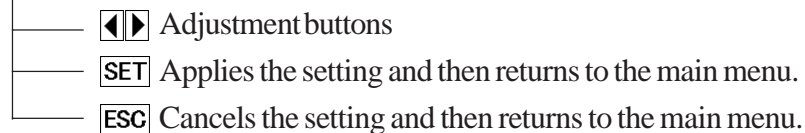

H-SIZE





4.2 Screen Display Adjustment



PHASE

-  Adjustment buttons
-  Applies the setting and then returns to the main menu.
-  Cancels the setting and then returns to the main menu.

DIM BACKLIGHT

-  Adjustment buttons
-  Applies the setting and then returns to the main menu.
-  Cancels the setting and then returns to the main menu.

AGC AUTO GAIN CONTROL (Analog RGB only)

-  Starts the auto gain control and then automatically returns to the main menu.
-  Returns to the main menu.





Be sure to perform auto gain control when the screen has both 100% black and 100% white areas displayed.



DSP DISPLAY MODE

-  Returns to the main menu.

RST OSD CLEAR

-  Clears the setting.
-  Cancels the setting and then returns to the main menu.

SYSTEM

-  Enables/disables the click sound. With this parameter, the sound level can also be adjusted.
(Default value: OFF <Click sound disabled>)
-  When an input data resolution of 720 x 400 is used in the VGA text mode, set this parameter to ON. For other resolutions, set this parameter to OFF.
(Default: OFF)

 **Reference** 2.3.1 Analog RGB Interface

4.2 Screen Display Adjustment

AUTO OFF DSP	<p>Enables/disables the screen display Auto OFF function and sets the time when the Auto OFF function is enabled. (Default: OFF <Auto OFF function disabled>)</p> <p>The Auto OFF function automatically turns off the display to prevent the screen from burning out when the touch panel is not used for some period of time. With this parameter, you can set the time interval to turn off the screen display (how much time passes before the screen display is turned off) when the touch panel is not used. If the touch panel is not touched over the set time, the backlight will automatically turns off.</p> <p>Select the time period from 1 min, 3 min, 5 min, 10 min, and OFF (Auto OFF function disabled).</p>
BL ALARM	<p>Enables/disables the Backlight burnout detect function. (Default: ON)</p> <p>When a burned-out backlight is detected, the status LED flashes alternately green and red, or a steady orange.</p> <p>Touch-operation will be disabled when the backlight burns out, which prevents the FP from sending input signals to the PLC.</p> <p> Normally, the FP unit detects a backlight burnout by monitoring the backlight's current flow, however, the FP may fail to detect this condition, depending on the type of backlight problem.</p>
POLARITY LOCK	<p>If an analog RGB interface is used and the horizontal display position exceeds the normally adjustable range, setting the POLARITY LOCK feature to ON may allow you to adjust the display position. (Default: OFF <Disabled>)</p> <p> This setting is enabled after the OSD is closed.</p>
SET	Applies the setting and returns to the main menu.
ESC	Cancels the setting and returns to the main menu.



Note:

In this screen, touching the value displayed on the panel changes the value of the time period.

4.2 Screen Display Adjustment

SAVE SAVE

Saves all the adjusted settings in the EEPROM.



- *In the OSD, pressing the **SET** button applies the set value and enables the setting. The set value won't be canceled unless the power is turned OFF or the value is reset.*

*If the power is turned OFF without saving the set value, that data will disappear. The last saved data will be read into the system when the FP starts. To enable the changed value, be sure to press the **SAVE** button.*

- *When the OSD automatically closes after 30 seconds of inactivity, the set value that you were modifying at the time will be retained. If you quit the OSD using the **ESC** button, the value you were modifying will be ignored and the previously set value will remain in effect.*

Memo

Chapter 5

Touch Panel Data

5.1 Touch Interface Data

1. Touch Interface Data
2. Touch Panel Communication Program for MS-DOS®

5.1 Touch Interface Data

The FP-2500/FP-2600 Series units use an analog type touch panel. This touch panel needs a calibration program to adjust the actual touch position.

■ Touch Panel Coordinate Data

The screen display origin point, with 640 x 480 for FP-2500 Series units and 800 x 600 for FP-2600 Series units, is normally at the upper left corner of the screen. Therefore, a software to convert the touch coordinates to display coordinates is needed.

(1) Resolution

Both the X and Y coordinates have a resolution of 1024.

The origin point (0,0) is located in the upper left corner of the screen.

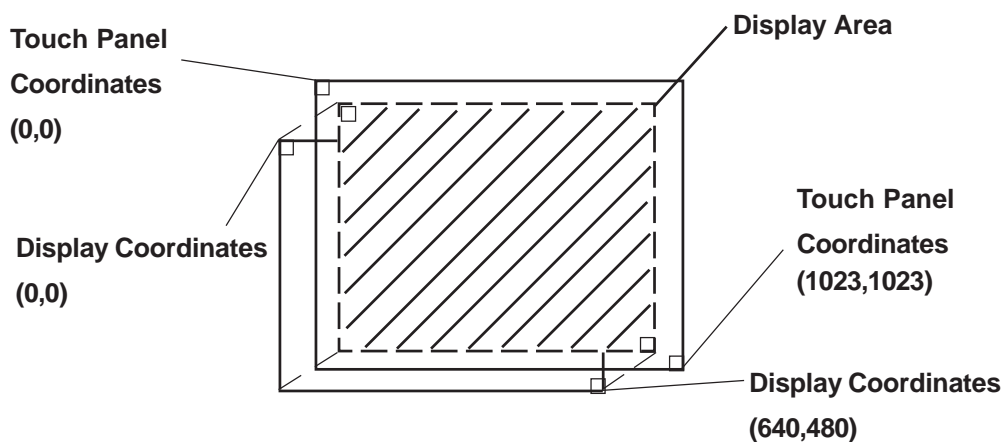

5.1 Touch Interface Data

(2) Data Format

Touch Panel coordinate data is sent to the host using the following format.

All data is in binary format.

Header: 1 byte (11h= touched; 10h = released)

X coordinate: 2 bytes (0 to 3FFh)

Y coordinate: 2 bytes (0 to 3FFh)

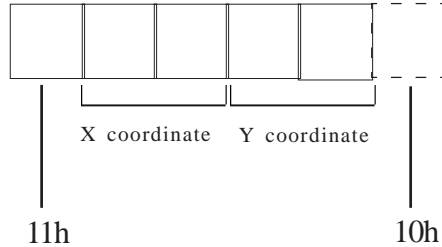

Added when touch is released.

<Example> If the coordinate (X=23(11h), Y=500(1F4h)) is touched and moved to the coordinate (X=63(3Fh), Y=250(FAh)).

11h 0h 17h 1h F4h	touched
11h 0h 17h 1h F4h	continuous output with the same location
11h 0h 18h 1h F3h	moving without releasing touch
•	•
•	•
•	•
•	•
11h 0h 3Fh 1h FAh	continuous data output unless finger is released
11h 0h 3Fh 1h FAh 10h	when released, only 1 unit of data is sent

■ Coordinate Data Conversion Software

OS	Touch Panel Handler	Calibration
Windows [®] 95, Windows [®] 98, WindowsNT [®] 4.0, Windows [®] 2000, Windows [®] XP	Mouse Emulator V2 (PL-TD000) ^{*1}	
MS-DOS [®]	FPATPH.EXE ^{*2*3}	FPCALIB.EXE ^{*2*3}

**1 Mouse Emulator V2 (PL-TD000) is optional software. This program is used for both English and Japanese.*



Mouse Emulator V2 cannot automatically detect your PC COM Port used to connect the FP unit.

As a result, select your PC COM Port via the Mouse Emulator V2 Installer window and enter the settings given in this manual for the Allocated I/O address and Interrupt.

When changing the COM Port on your PC used to connect the FP unit, change the setting using Window's [Start]-[Program]-[Updd]-[Operation Setup]-[Hardware].

**2 These programs are contained in the CD-ROM.*

▼Reference▲ About CD-ROM

**3 These programs are only for the FP-2500 Series units. FP-2600 Series units cannot be used.*

▼Reference▲ 5.2 Touch Panel Communication Programs for MS-DOS[®]

5.1 Touch Interface Data

5.2 Touch Panel Communication Programs For MS-DOS®

When using MS-DOS® on the FP-2500 Series units, MS-DOS® Touch Panel Communication Programs for MS-DOS® are required. These programs are contained in the CD-ROM.

 **Reference** *CD-ROM Data*



- When using a host device that does not have a CD-ROM Drive unit, copy these programs to a floppy disk.



- **These programs run only on PC/AT compatible machines using MS-DOS. Therefore, do not use a USB cable.**
- **These programs are only for FP-2500 Series units. FP-2600 Series units cannot be used.**

5.2.1 FPATPH.EXE (Touch Panel Handler)

■ How to Operate the Software

FPATPH [parameter] or FPATPH -r 

* Parameter Explanation

-a <n>Selects the I/O address of the SIO port where the touch panel

is connected.

(hexadecimal, default = 2f8)

n = 3f8 (COM1)

2f8 (COM2)

-q <n>Selects the interrupt level (IRQ) for the SIO port where the touch panel is connected. (default = 3)

n = 4 (COM1)

3 (COM2)

-i <n> Sets the vector number for the function call's software interrupt. (hexadecimal, default = 59)

-r Removes the current (resident) memory command.

-c <path> Specifies the data file made by FPCALIB.EXE (touch panel data FPcalibration) that contains the correction value.

"FPATPH. CAL" in the current directory is selected for default.

5.1 Touch Interface Data

When this program runs, the following message will display on the screen.

Analog Touch Panel Handler FPATPH. EXE Version 1.**
Copyright (c) 1993 Digital Electronics Corporation
Stay resident.

After execution, the command stays in memory.



When the data file made by FPCALIB. EXE is not found or cannot be opened, the following message appears. In such a case, the program will run without data correction.

WARNING !! Can't open CAL file.
Stay resident.

If data correction is not carried out successfully, the display position may not match with the touch panel input position.

■ Function

FPATPH. EXE has the following functions, which are activated by software interrupt (Default = INT59H) function calls.

< INT 59H Function List >

Function Code	Contents
8100h	Touch panel input (infinite wait)
8101h	Touch panel input (instant return)
8102h	Non-destructive input
0200h	Input buffer clear
8500h	Detection of touch panel's condition
FE00h	Resident Confirmation

■ Function Explanation

Function 8100h Touch panel input (infinite wait)

Returns touch coordinates. Waits infinitely for input.

< input > AX = 8100h

< output > AH = 0 : normal termination

 BX = Y : coordinate (0 - 479)

 DX = X : coordinate (0 - 639)

 CX = Number of effective input buffers for the analog touch panel.

5.1 Touch Interface Data

Function 8101h	Touch panel input (instant return)
----------------	--------------------------------------

Returns touch coordinates. Will quit the function if there is no input.

< input > AX = 8101h

< output > AH = 0 : input

1 : no-input

BX = Y : coordinate (0 - 479)

DX = X : coordinate (0 - 639)

CX = Number of effective input buffer for the analog touch panel.

Function 8102h	Non-renewing touch panel input
----------------	--------------------------------

Sends the position coordinates, and does not renew the panel's input buffer.

< input > AX = 8102h

< output > AH = 0 : input

1 : no-input

BX = Y : coordinate (0 - 479)

DX = X : coordinate (0 - 639)

CX = Number of effective touch panel input buffers.

Function 0200h	Input buffer clear
----------------	--------------------

Clears the touch panel's input buffer.

< input > AX = 0200h

< output > AH = 0 : normal end

Function 8500h	Detection of touch panel condition
----------------	------------------------------------

Returns the touch panel condition

< input > AX = 8500h

< output > AH = status at 640 x 480 mode

Bit 1	Bit 0	Contents
0	0	touched
0	1	no-change
1	0	(not used)
1	1	released

5.1 Touch Interface Data

Function FE00h	Confirmation of resident memory
----------------	---------------------------------

If FPATPH.EXE is resident in memory, a fixed message and its version number are returned.

< input > AX = FE00h

< output > AH = 0 : normal termination

BL = 'Y'

BH = 'B'

CX = version number

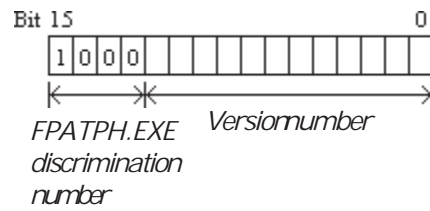

Carry = clear

5.1 Touch Interface Data

5.2.2 FPCALIB.EXE (Touch Panel Data FPCalibration)

Because of changes in operational environment and the unit's deterioration, differences in theoretical and actual touch coordinates arise; and therefore these differences must be corrected periodically, via a utility software called FPCALIB.EXE (touch panel data FPCalibration).

By touching the designated position on the display (upper left and lower right), FPCALIB.EXE calculates the difference between the theoretical and actual coordinates. Then, from the result, a correction data file to be used by FPATPH (touch panel handler) is made.

■ How to Operate

FPCALIB -d [parameter]

* Explanation of parameters

- a <n> Selects the I/O address of the SIO port where the touch panel is connected. (hexadecimal, default = 2f8)
n = 3f8 (COM1)
2f8 (COM2)
- q <n> Selects the interrupt level (IRQ) for the SIO port where the touch panel is connected. (default = 3)
n = 4 (COM1)
3 (COM2)
- c <path> Specifies the data file made by FPCALIB.EXE (touch panel data FPCalibration) that contains the correction value.



Note: When the touch panel is connected to COM2, the default value can be used.

■ Operation Procedure

```
■ Analog Touch Panel Calibration FPCALIB.EXE
  Version 1.**
  Copyright(c)2000 Digital Electronics Corporation

  Calibration Mode

  Touch upper left and lower right corner of the
  screen.
  [Enter] : Go to test mode.
  [Esc]  : Terminate program.
  Upper left  Lower right
  (0000,0000) (0000,0000)
  ■
```

- 1) When FPCALIB. EXE is executed, the message on the left displays on the screen. Then the two designated position, upper left and lower right corners, starts to blink.

5.1 Touch Interface Data

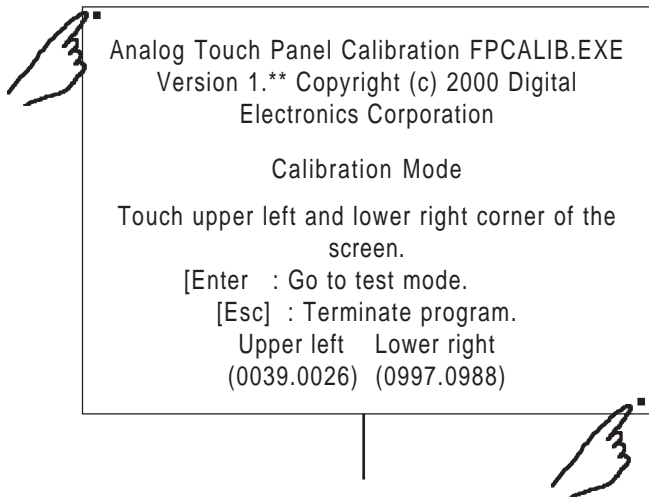

Terminate program without saving calibration data?(Y/N)

- 2) Touch the designated positions, one after the other. Correction data will be calculated from the difference between the actual and the theoretical values. The actual value is shown on the display.



- Do not touch two points at the same time.
- Touch right above the designated position.
- By re-touching the points, the actual coordinates will redisplay.



Note: Press the [Esc] key to terminate the program. Press the [Y] key after the message on the left is shown, and the program will terminate without saving any FPcalibration data. If the [N] key is pressed, the system will return to "FPcalibration mode".

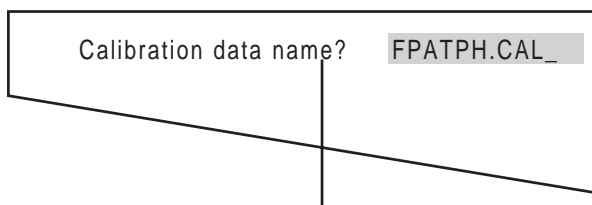
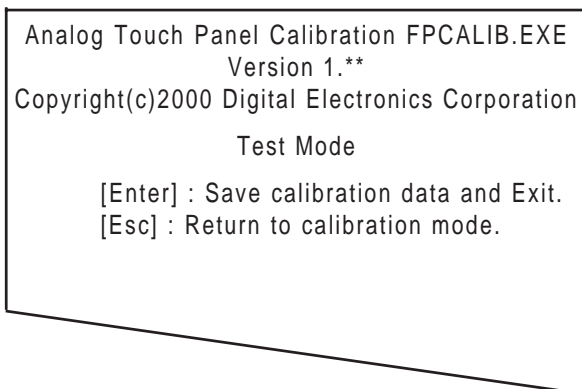

Enter the file name

- 3) The "test mode" tests whether the FPcalibration has been processed correctly or not. To enter "test mode", press the [Enter] key. The FPcalibration is confirmed as successful if the locus shown on the display matches as touched. Otherwise, return to the "FP calibration mode" and redo the FPcalibration by touching the right blinking position.



Note: Press the [Esc] key to return to "FPcalibration mode".

- 4) If the test result is OK, press the [Enter] key. After the following message appears, enter the name of the data file and press the [Enter] key.



Note: When the data filename is specified from the parameter (-C=[path]) during the execution of FPCALIB.EXE, the program will terminate without showing the message on the left.

Memo

Chapter 6

Troubleshooting

1. Troubleshooting
2. Error Message

6.1 Troubleshooting

6.1.1 Possible Device Problems

This section assumes that the FP is the cause of a problem, not the host.



Note: • When the host is the problem, please refer to its corresponding manual.

Possible types of trouble while using this unit are as follows.

Screen does not display normally

- No display appears after the unit is switched on.
- The screen disappears during standard operation.
- The screen does not display normally.

Touch panel does not respond

- The touch panel does not respond when pressed.
- The touch panel reaction time is abnormally long.

6.1 Troubleshooting

6.1.2 No Display

When the screen does not display when powering up, or if the screen turns OFF by itself, use the flowchart below to find an appropriate solution.

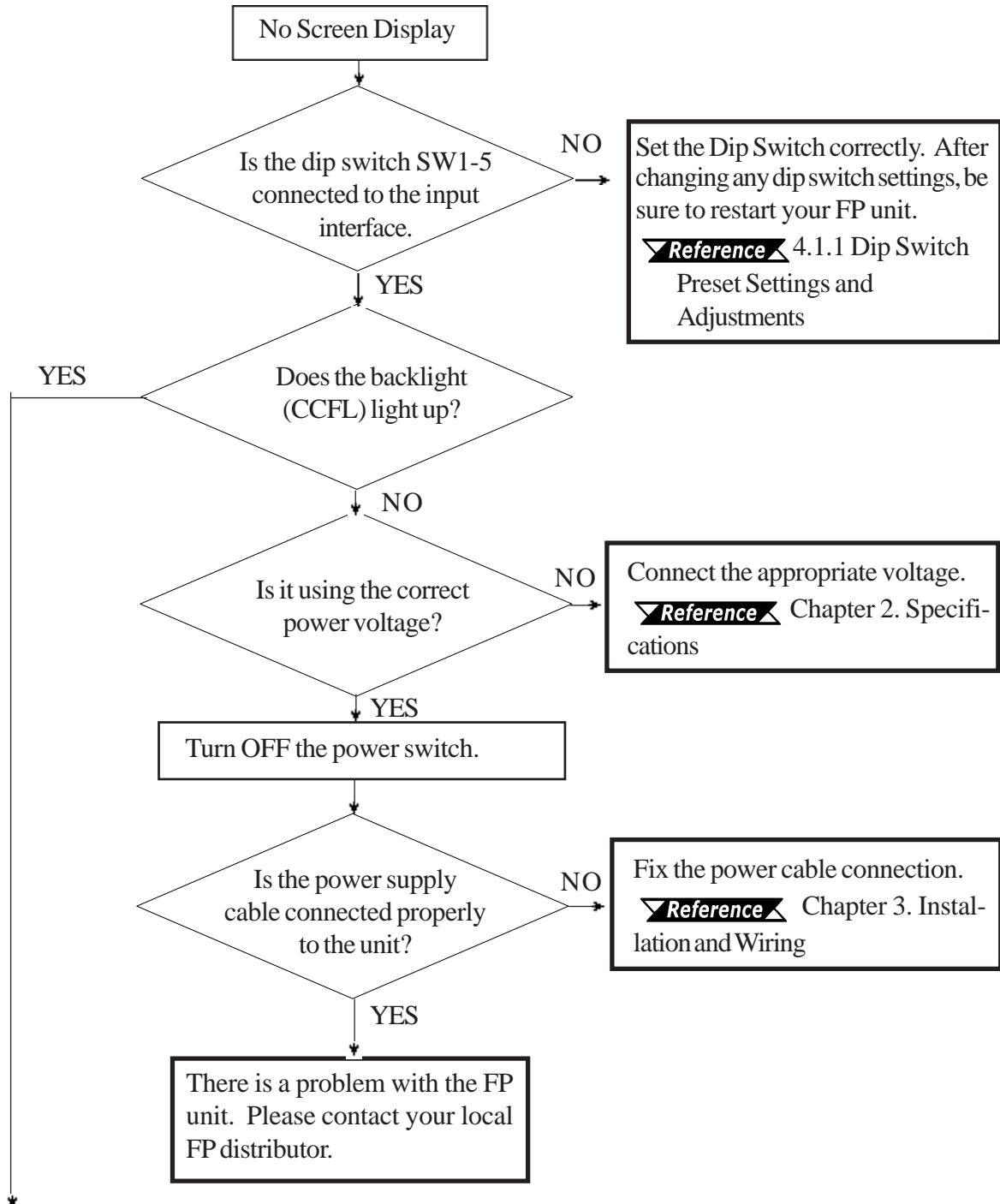

6.1 Troubleshooting

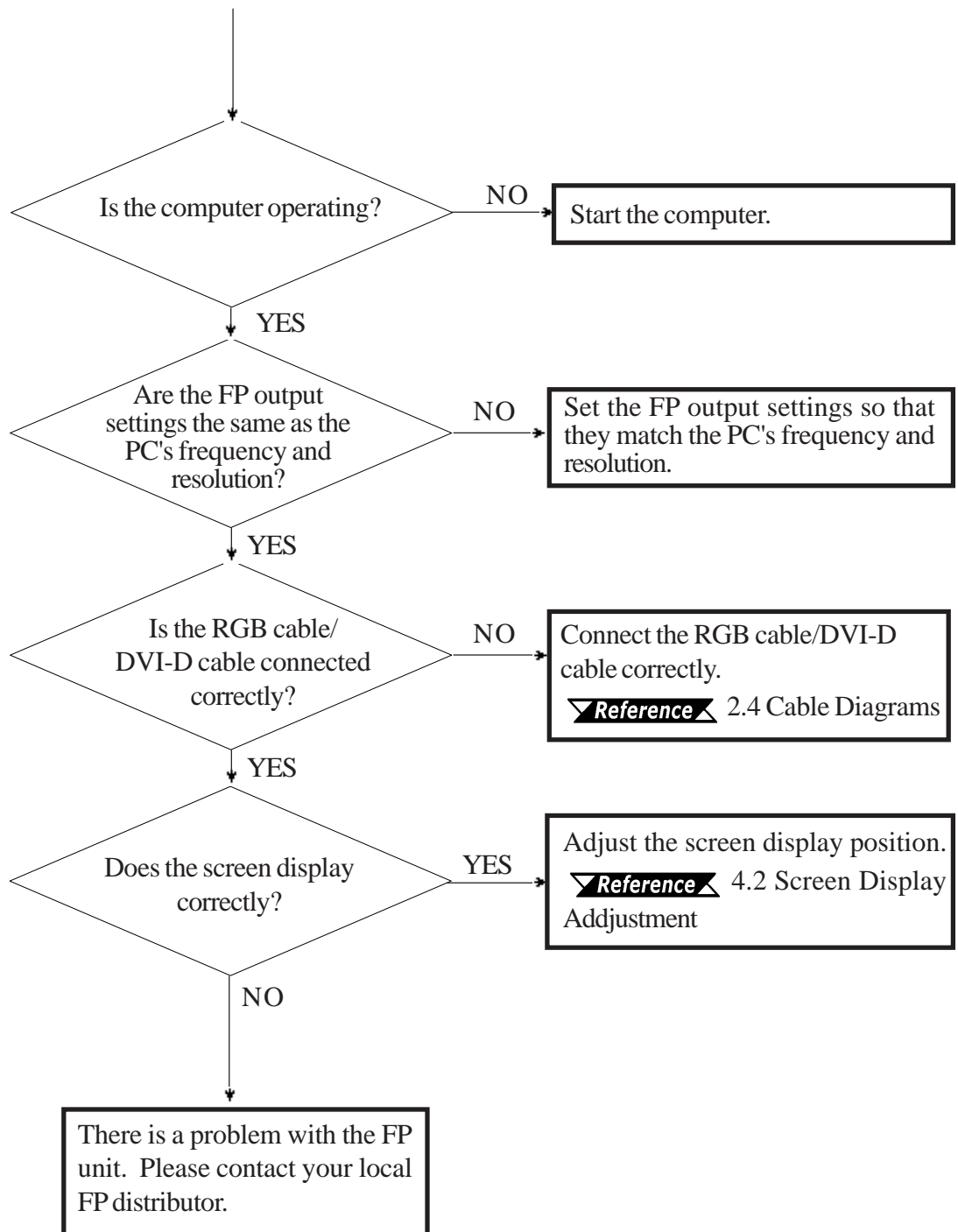

6.1 Troubleshooting

6.1.3 Touch Panel Does Not Respond

When the touch panel does not react, or its reaction is very slow after it is pressed, follow the flowchart below to find the origin of the problem and the appropriate solution.

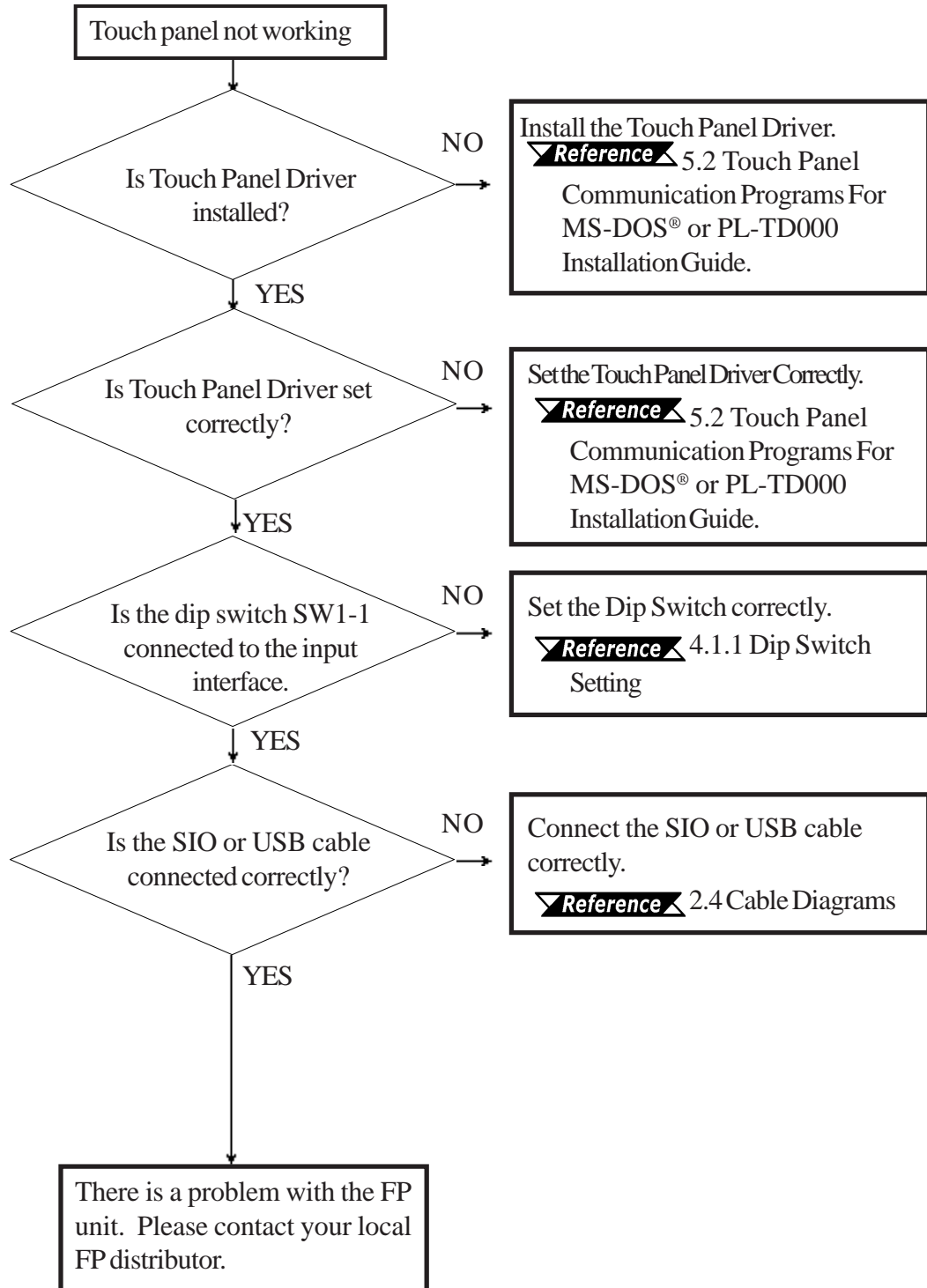

6.2 Error Message

This section explains the messages that appear when an error has occurred in the FP unit during RUN mode. The problem causing the error message and its related countermeasure are explained in the table below.

(Only the latest error message will appear on the FP screen)

6.2.1 Error Message List

Error Message	Problem	Countermeasure
Out of Range 1 to 3	Signal timing has been input that is not compatible with the FP unit.	Set the FP output settings so that they match the PC's frequency and resolution. ▼Reference▲ 2.3 Interface Specifications
	The dot clock has greatly exceeded of the FP unit's usable timing range.	
	Resolution has been set that is not compatible with the FP unit.	
No Signal	The PS-2000B unit or a Windows-compatible PC's power has not been turned ON.	Turn on the PS-2000B unit or a Windows-compatible PC's power.
	The PS-2000B unit or a Windows-compatible PC has not been correctly connected to the FP unit.	Connect the RGB cable/DVI-D cable correctly.
	The input I/F and the image input signal type are not the same.	Set the Dip Switch correctly. ▼Reference▲ 4.1.1 Dip Switch Preset Settings and Adjustments

Memo

Chapter 7

Maintenance

1. Regular Cleaning
2. Periodic Check Points
3. Backlight Replacement

7.1 Regular Cleaning

7.1.1 Cleaning the Display

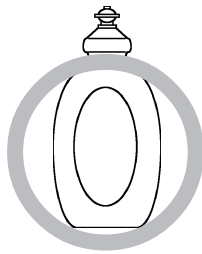

Neutral detergent

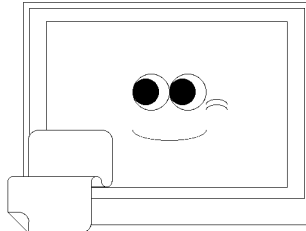

When the display surface or frame become dirty, use a soft cloth moistened with neutral detergent to wipe away any dust or stains.

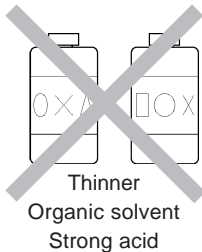

Thinner
Organic solvent
Strong acid

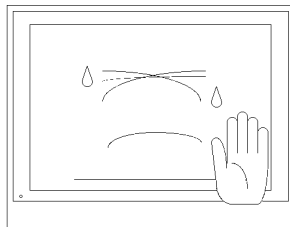

Do not clean the unit with thinner, organic solvents, or strong acids.

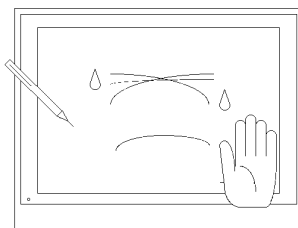

Do not use sharp or hard objects, such as a mechanical pencil or screwdriver, to push on the display. This could damage the unit.

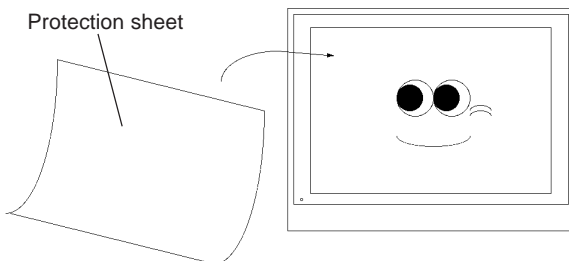

Attach the screen protection sheet when using the FP in extremely dirty or dusty areas.

7.1 Regular Cleaning

7.1.2 Installation Gasket Replacement

The installation gasket protects the FP and improves its water resistance. For instructions on installing the FP unit's gasket, refer to

Reference *Chapter 3 Installation and Wiring*



A gasket which has been used for a long period of time may have scratches or dirt on it, and could have lost much of its water resistance. Be sure to change the gasket at least once a year, or when scratches or dirt become visible.

■ Installation Gasket Replacement Procedure

- 1) Place the FP on a flat, level surface with the display facing downwards.
- 2) Remove the old gasket from the FP.
- 3) Attach the new gasket to the FP. Be sure to insert the gasket into the FP unit's groove so that the gasket's groove sides are vertical.
- 4) Check if the gasket is attached to the FP correctly. The upper surface of the gasket should protrude approximately 2mm out from the groove.

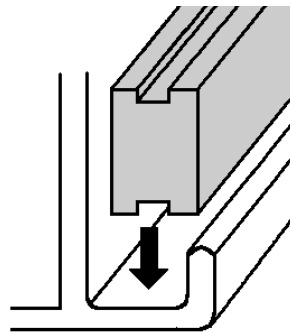



- **The gasket must be inserted correctly into the groove for the FP unit's moisture resistance to be equivalent to IP65f.**
- **Be sure the gasket's seam is not inserted into any of the unit's corners, only in the straight sections of the groove. Inserting it into a corner may lead to its eventually tearing.**
- **The upper surface of the gasket should protrude approximately 2mm out from the groove. Be sure to check that the gasket is correctly inserted before installing the FP into a panel.**

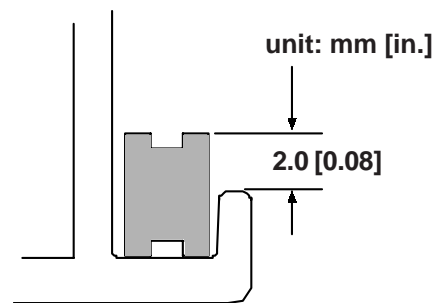

7.2 Periodic Check Points

To keep your FP unit in its best condition, please inspect the following points periodically.

FP Operation Environment

- Is the ambient temperature within the allowable range (0°C to 50°C)?
- Is the ambient humidity within the specified range (30%RH to 90%RH, dry bulb temperature of 39°C or less)?
- Is the operating atmosphere free of corrosive gasses?

Electrical Specifications

- Is the Rated Voltage Range appropriate ?

FP Model Number	Rated Voltage Range
FP2500-T12 FP2600-T12	AC85 to 264V
FP2500-T42-24V FP2600-T42-24V	DC19.2 to 28.8V

Related Items

- Are all power cords and cables connected properly? Have any become loose?
- Are all installation fasteners holding the unit securely?
- Are there any scratches or traces of dirt on the installation gasket?

7.3 Backlight Replacement

7.3 Backlight Replacement

The backlight is a cold-cathode tube. Although the FP uses a long-life backlight, replacement may be required earlier than expected depending on the environment where the FP is used.

The life span of the backlight is as follows:

(Time period until the backlight becomes half as bright as a new one)

50,000 hours (approx. 5.7 years)

When a burned-out backlight is detected, the status LED flashes alternately green and red, or a steady orange.

WARNINGS

- To prevent an electric shock, be sure to turn the FP unit's power OFF before replacing the backlight.
- The backlight and the FP itself will be very hot just after turning off the power. To avoid burning your skin, be sure to wear gloves when replacing the backlight.
- The backlight is very fragile. To avoid possible injury, do not directly touch the glass or pull the cable.



- *Normally, the FP unit detects a backlight burnout by monitoring the backlight's current flow. However, the FP may fail to detect backlight burnout, or may only detect it before the backlight burns out completely, depending on the type of backlight problem.*



- Please check that the replacement backlight is compatible with the FP.

FP Model	Rev.	Backlight Model
FP-2500 Series	-	GP577RT-BL00-MS
FP2600-T12	Rev.1 is not marked. ^{*1}	PS600-BU00
FP2600-T42-24V	Rev.1 is not marked. ^{*1}	
FP2600-T12	Rev.1 is marked. ^{*1}	CA3-BLU12-01
FP2600-T42-24V	Rev.1 is marked. ^{*1}	

**1 The corresponding backlight unit differs depending on FP-2600 Series unit's marked Revision.*

Reference For more information on how to determine the revision version, see "Revision Version" (Page 10).

7.3 Backlight Replacement

■ Backlight Replacement

Follow the procedures given below to replace the FP unit's backlights. Be sure to wear gloves during replacement.



- ***Be sure to protect the FP front panel's surface to prevent damage.***
- ***The FP-2500 Series units have an upper and a lower backlight. Be sure to replace both.***
- ***The FP-2600 Series units have only one backlight.***

7.3 Backlight Replacement

7.3.1 Replacing GP577RT-BL00-MS

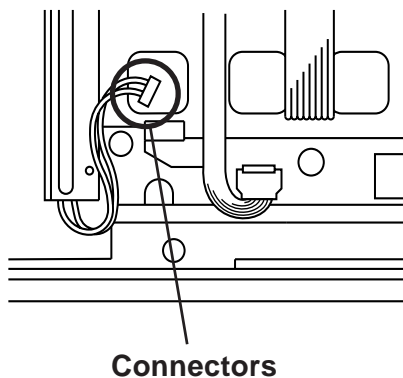
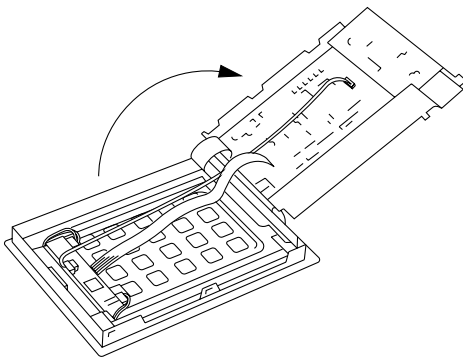
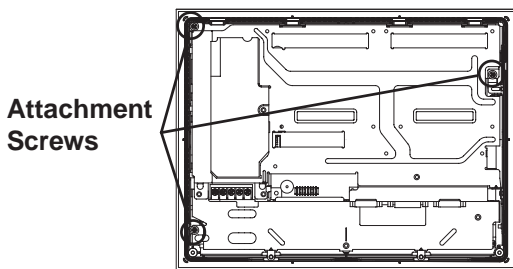
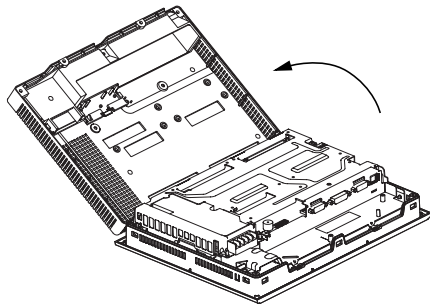
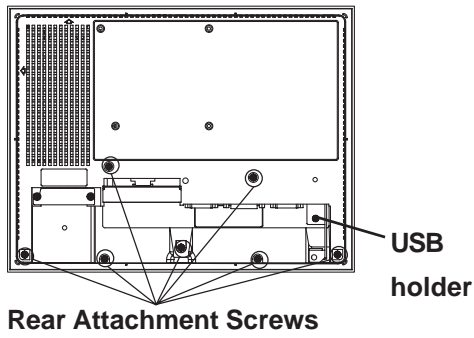

- 1) Turn the FP unit's power OFF (i.e. disconnect the FP unit's power cord). Use a Phillips screwdriver to remove the case's seven (7) rear attachment screws and USB holder. Pivot the rear cover open, starting from the top of the unit.
- 2) The cover is fastened at the bottom, and hinges open.



- **Be sure not to break the rear cover's four (4) alignment tabs when you open it.**
- **To prevent FP unit damage, be sure the FP unit's rear cover open/close direction is correct.**

- 3) Loosen the three (3) circuit board attachment screws.

- 4) The circuit board is connected on one side, and hinges open.



- **When the FP unit's power has just been turned OFF, the circuit board chassis is still very hot! Be sure to wear gloves to prevent being burned.**

- 5) Disconnect the upper backlight's two (2) power connectors.

7.3 Backlight Replacement

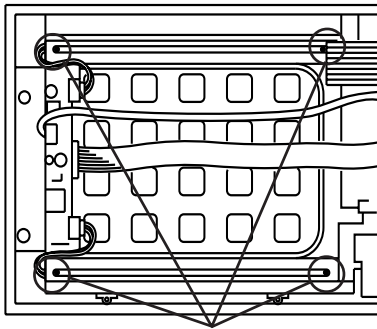

Attachment Screws

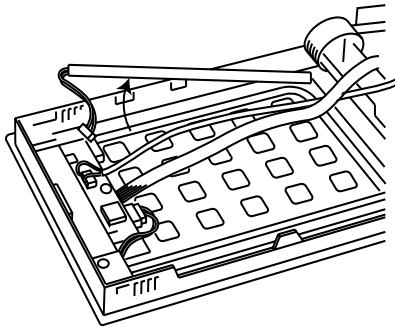

Upper Section

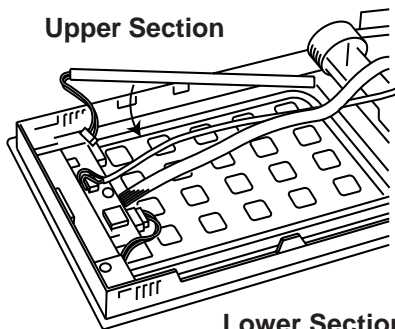

Lower Section

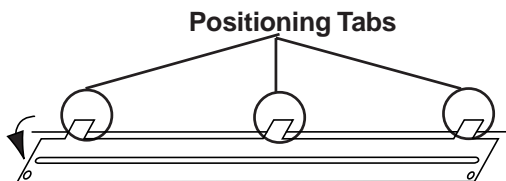

Positioning Tabs

- Loosen the upper and lower backlight holder attachment screws, and remove the upper backlight unit's metal cover.



Important

Since the attachment screws are small, be sure not to lose them or allow them to fall inside the FP's case.

- Remove the old backlight.

- Insert the new backlight.



Important

The FP unit's upper and lower backlights are different. Be sure to confirm that the backlight you are replacing is the correct unit by looking at the side of the backlight connector.

If the backlight has an arrow here, it is used only for the upper backlight.

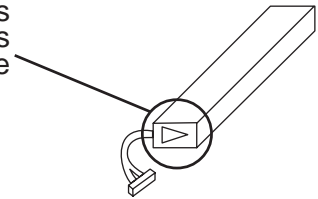

- Insert the metal cover's three (3) positioning tabs into the LCD holder's positioning slots. Next, insert and tighten the cover's two (2) attachment screws.

- Reattach the backlight unit's power connector. Repeat these steps for the FP unit's bottom backlight unit.

- After both backlight units are changed and the power connectors reattached, close the rear case and reattach the case's two attachment screws.

7.3 Backlight Replacement



- **Be sure not to pinch or cut any of the FP unit's internal wiring when closing the case.**
- **If any of the attachment screws becomes misplaced, check to be sure that they have not fallen inside the FP. If a screw has fallen inside the FP, do not connect the unit's power cord.**

7.3.2 Replacing PS600-BU00

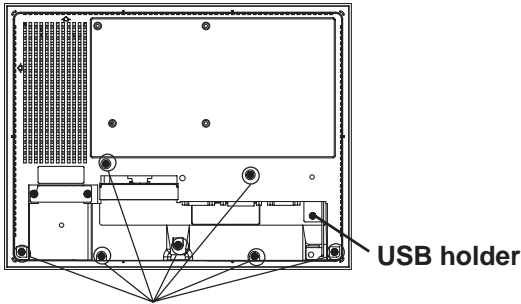

Rear Attachment Screws

- 1) Turn the FP unit's power OFF (i.e. disconnect the FP unit's power cord). Remove the three (3) I/F covers, and use a Phillips screwdriver to remove the case's seven (7) rear attachment screws and USB holder. Pivot the rear cover open, starting from the top of the unit.



Since the attachment screws are small, be sure not to lose them or allow them to fall inside the FP unit's case.

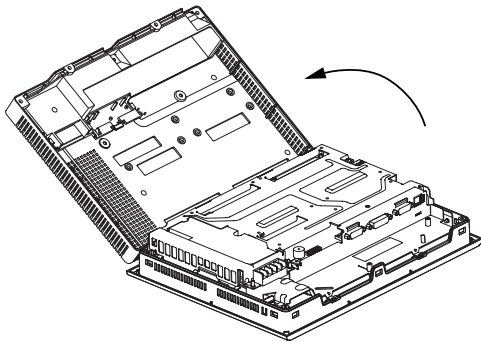

- 2) The cover is fastened at the bottom, and hinges open.



- **Be sure not to break the rear cover's four (4) alignment tabs when you open it.**
- **To prevent FP unit damage, be sure the FP unit's rear cover open/close direction is correct.**

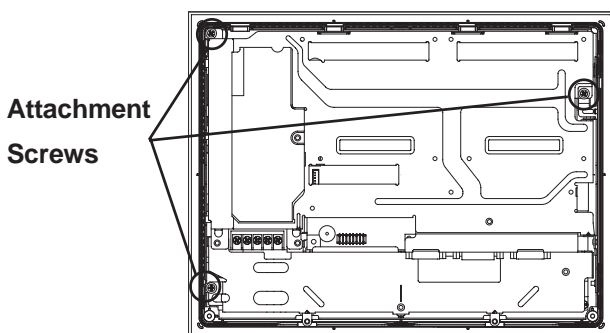

- 3) Loosen the three (3) circuit board attachment screws.

7.3 Backlight Replacement

- 4) The circuit board is connected on one side, and hinges open.

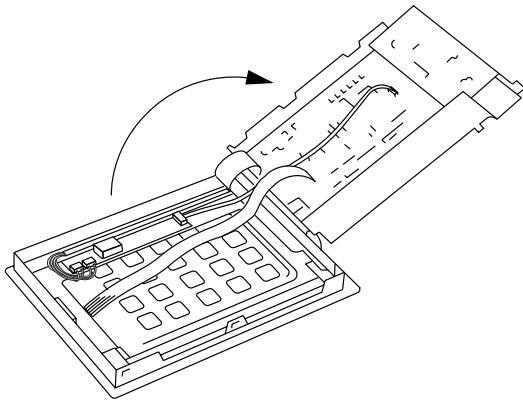

When the FP unit's power has just been turned OFF, the circuit board chassis is still very hot! Be sure to wear gloves to prevent being burned.

- 5) Disconnect the backlight's two (2) power connectors.

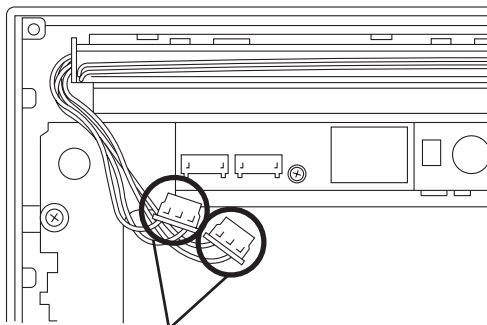

Connector

- 6) Loosen the backlight unit attachment screw (the screw cannot be separated from the backlight unit), slide the backlight in the direction shown and remove it from the FP.

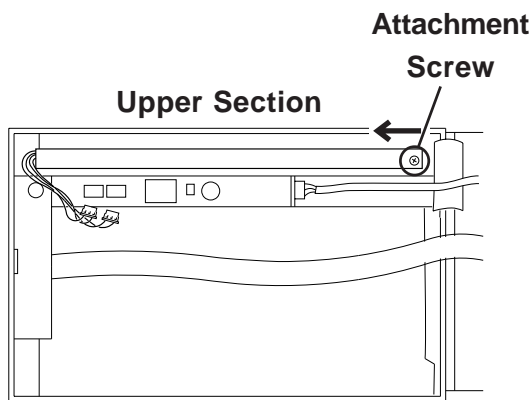

Lower Section

- 7) Insert the new backlight in the FP. Insert the unit by sliding it in the direction shown in step 6), then, tighten the unit's attachment screw.

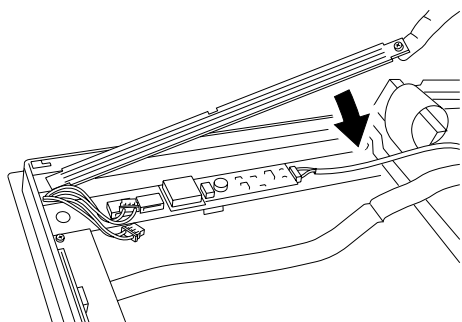
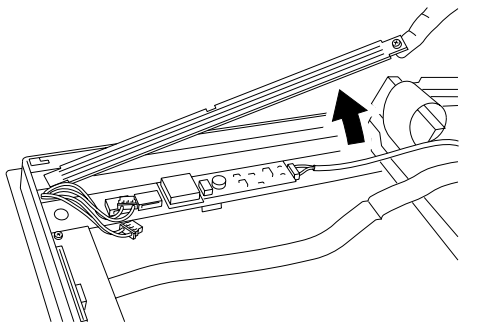

- 8) Connect the backlight's two (2) power connectors. Next, close the circuit board and secure the rear case in place using the attachment screws removed in steps 1), 2) and 3).

7.3 Backlight Replacement



- **Be sure not to pinch or cut any of the FP unit's internal wiring when closing the case.**
- **If any of the attachment screws becomes misplaced, check to be sure that they have not fallen inside the FP. If a screw has fallen inside the FP, do not connect the unit's power cord until it has been removed.**

7.3.3 Replacing CA3-BLU12-01

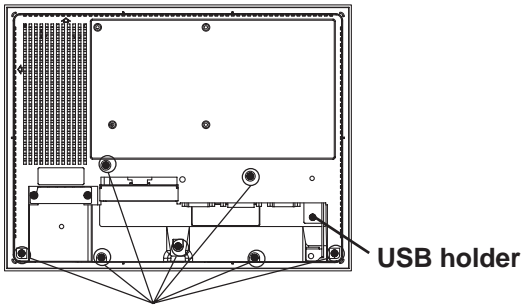

Rear Attachment Screws

- 1) Turn the FP unit's power OFF (i.e. disconnect the FP unit's power cord). Remove the three (3) I/F covers, and use a Phillips screwdriver to remove the case's seven (7) rear attachment screws and USB holder. Pivot the rear cover open, starting from the top of the unit.



Since the attachment screws are small, be sure not to lose them or allow them to fall inside the FP unit's case.

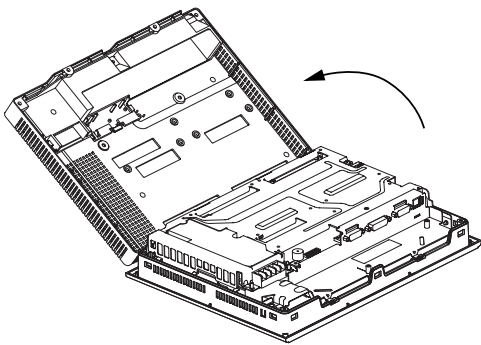

- 2) The cover is fastened at the bottom, and hinges open.



- **Be sure not to break the rear cover's four (4) alignment tabs when you open it.**
- **To prevent FP unit damage, be sure the FP unit's rear cover open/close direction is correct.**

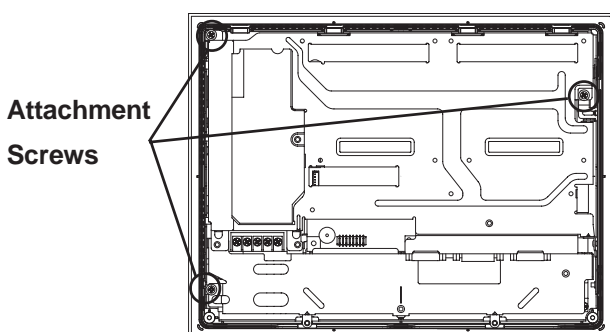

- 3) Loosen the three (3) circuit board attachment screws.

7.3 Backlight Replacement

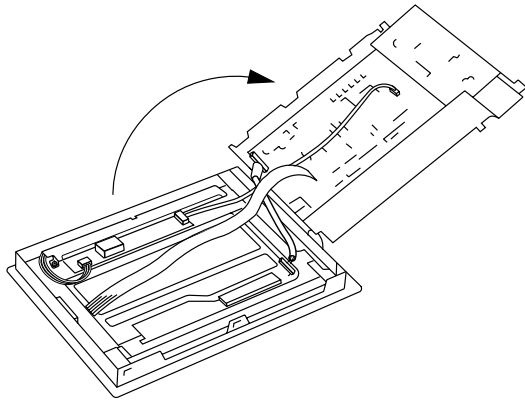

- 4) The circuit board is connected on one side, and hinges open.



When the FP unit's power has just been turned OFF, the circuit board chassis is still very hot! Be sure to wear gloves to prevent being burned.

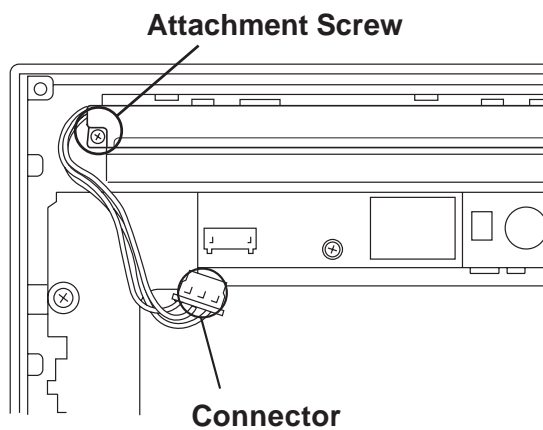

- 5) Disconnect the backlight's one (1) power connector.

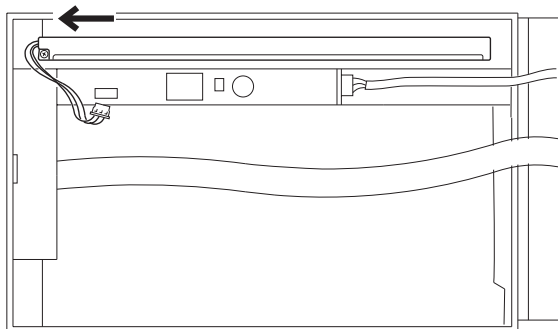

- 6) Loosen the backlight unit attachment screw. Next, slide the backlight in the direction shown and lift it forward and remove it from the FP.

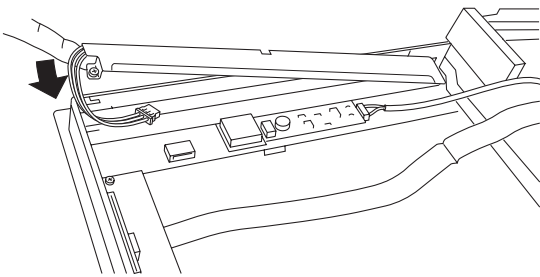

7) Insert the new backlight in the FP. Insert the unit by sliding it in the direction shown in step 6).

8) Connect the backlight's one (1) power connector. Next, close the circuit board and secure the rear case in place using the attachment screws removed in steps 1), 2) and 3).



- ***Be sure not to pinch or cut any of the FP unit's internal wiring when closing the case.***
- ***If any of the attachment screws becomes misplaced, check to be sure that they have not fallen inside the FP. If a screw has fallen inside the FP, do not connect the unit's power cord until it has been removed.***